

Technical specifications

QI 630

Voltage: 400/230 V

Frequency: 50HZ



Genset Image for illustration purposes only

TECHNICAL INFORMATION

Standby Power (ESP)	kVA	630
	kW	504
Prime Power (PRP)	kVA	571
	kW	457
Mechanical structure	Open skid on baseframe	
Engine	DOOSAN DP180 LA	
Alternator	MECC ALTE ECO40-1,5L	
Control card	DEEP SEA 7320	
Measures (L x W x H)	mm	3.325 x 1.800 x 2.315
Empty weight	kg	4.155
Fuel tank	L	1.079

Voltages	Prime Power (PRP)		Standby Power (ESP)	
	(kVA)	(kW)	(kVA)	(kW)
380/220	571	457	630	504
400/230	571	457	630	504
415/240	571	457	630	504

Notes:

PRIME POWER: Electrical power data available at a variable load without limits of hours per year. An overload of 10 % is allowed for 1 hour of every 12. In accordance with ISO 8528/1 (2005) – PRP

STANDBY POWER: Electrical power data at variable load in an emergency in accordance with standard ISO 8528/1 (2005) – ESP. Overloads of emergency power are not allowed.

The standard reference conditions are: 25 °C, 100 kPa and 30% relative humidity. Gasoil density: 0.85 g/cm3. Gasoline density: 0.68 g/cm3.

■ INDEX

General description
Engine
Alternator
Bedplate
Electric Panel
ATS
Dimensions and Weight
Performance class
Regulation
Annex: Drawings

Grupos Electrógenos Europa, S.A. is a certified company with ISO 9001, ISO 14001, OHSAS 18001 and PECAL

We reserves the right to modify any characteristic of their equipment without prior warning.

Photographs representing the product range, while able to include options.

Weight and dimensions of a standard generator set.

Non-contractual document

Central Offices:

Polígono Industrial Pitarco II; Parcela 20

50450 Muel (Zaragoza) Spain

Tel.: +34 976 14 54 32

Fax: +34 976 14 54 31

info@gesan.com

After-sales Department:

Customer service: +34 976 14 54 33

Spare parts: +34 976 14 54 34

GENERAL DESCRIPTION

Generator set for automatic operation due to a grid failure, including the electrical operations panel, installed on a bedplate. Start-up of the generator set will be carried out when a failure in the grid power supply is detected. Once the generator set has stabilized, a signal is sent to the switching panel to switch the grid position to generator set. When the grid power supply return is detected, a command is sent to the switching to switch to the generator set position of the grid. The generator set shuts-down after the applicable cooling period has elapsed.

ENGINE

Doosan diesel engine, with turbo, with direct injection and Electronic regulation of the engine.

Engine brand	DOOSAN	Bore (mm)	128
Model	DP180 LA	Stroke (mm)	142
R.P.M.	1.500	Compression ratio	15:1
Net power (kWm)	536	Type of regulation	Electronic
Fuel	Diesel	Europe exhaust emission	EU0
No. of cylinders	10 V (90°)	EPA exhaust emission	N/A
Engine Capacity (c.c.)	18.273		

Cooling System

Cooling of the sleeves using cooling fluid comprised of water and glycol at 50% in a closed circuit driven by the engine pump.

Engine driven exhaust fan, radiator and expansion tank; original from the engine manufacturer.

The circuit is completed with the cooling purge system towards the outside of the bedplate and protections of all running surfaces

Flow of air from fan (m³/min)	700	Coolant capacity (l)	91
Cooling type	Water	Design temperature radiator (°C)	52°C

Lubrication System

Gear pump lubrication system driven by the engine and with original engine manufacturer lubricant filtering system.

It is completed with the oil purge system towards the outside of the baseframe.

Oil capacity (l)	34	Medium oil consumption (% fuel consumption)	0,5
-------------------------	----	--	-----

Air intake system

Air intake system for combustion with filtering device and filter change indicator; originals from the engine manufacturer. Intake air cooling after the turbo by means of an air/air exchanger.

Intake air flow (m³/min)	33	Air inlet filter type	Medium
--	----	------------------------------	--------

Exhaust System

Interior and exterior aluminized steel exhaust silencer.

T^a gas emission (°C)	562	Gas flow (m³/min)	106
--	-----	-------------------------------------	-----

Start system

Start system that uses an electrical motor, battery, battery disconnecter and battery charge alternator that is driven by the engine itself. The start motor and the battery charge alternator are originals from the engine manufacturer.

Lead acid battery with Spiralcell® recombining technology, sealed structure to prevent leaks, maintenance free, large start-up capacity maintaining the voltage due to its low internal resistance and small volume thanks to its rolled plates design that guarantees it will withstand many discharges with large temperature changes.

Starter voltage system (V)	24	Battery type	2 x 12V 44Ah - 730A
-----------------------------------	----	---------------------	---------------------

Fuel supply system

Fuel intake system original from engine manufacturer with filter.

Fuel tank capacity (L)	1.079
-------------------------------	-------

Fuel consumption panel (range according to the standard configuration)

Load	Prime Power (PRP)		Standby Power (ESP)	
	(l/h)	Range (h)	(l/h)	Range (h)
25%	35	31	38	28
50%	65	16,7	71	15,3
75%	94	11,5	103	10,5
100%	124	8,7	135	8

ALTERNATOR

Mecc Alte alternator with 4 poles, with a lifetime lasting greased bearing, H class insulation, without brushes, 2/3 coil and AVR (Automatic Voltage Regulator)

Protection of all the windings by means of 2-part high quality polyester resin impregnation. The stator windings receive a double impregnation. Final finish with a coat of EG43 varnish.

Excitation system with MAUX auxiliary winding with overload capacity 3 times the nominal current for 20 s.

Joining of engine and alternator through flexible disc coupling.

Regulations:

- CEI 2-3
- IEC 34-1
- EN 60034-1
- VDE 0530
- BS 4999-5000
- CAN/CSA-C22.2 No14-68-No100-95
- ISO 8528:3

Low wave distribution:

- THC < 4%
- THD < 4%
- THF (IEC) < 2%
- TIF (NEMA) < 40

Incorporates electromagnetic emissions suppressor in accordance with standard VDE 0875, class K.

Brand	MECC ALTE	Voltage Stability	±1%
Model	ECO40-1,5L	Performance at 75% p.f. 0.8 (%)	95
Alternator Power (kVA)	670 / Standby (SB27)	Performance at 100% p.f. 0.8 (%)	95
Number of wires	12	Direct subtransient reactance X''d (%)	9,8
IP Alternator	IP 21	Subtransient time constant, T''d (ms)	19
Excitation system	MAUX	Zero sequence reactance, Xo (%)	2,7
AVR model	DSR	Short-circuit ratio, Kcc	0,4

▪ BEDPLATE

The engine-alternator set is coupled to the bedplate by means of anti-vibration shock mounts that absorb almost all the vibrations.

The fuel tank is integrated and joined to the bedplate using hardware, which allows disassembling it for maintenance or replacement. It has a drainage plug, wide cleaning cover and filler connection with plug.

Includes level sensor with low fuel alarm signal that indicates the amount of fuel available in the tank to the electrical panel.

▪ ELECTRIC PANEL

Electrical panel integrated in the generator set with digital control plate.

Has a single-pole circuit breaker, manually actuated, with thermal-magnetic protection against overloads and short-circuits.

Circuit Breaker rated current (A)	4P 1250A R	Battery charger	DSE 9255 - 24V 5A
--	------------	------------------------	-------------------

Has a DEEP SEA battery charge maintainer, designed to be permanently connected to the battery and maintains it charged to its maximum capacity.

Has no moving parts. The charger switches to floating mode when the charge is complete

Control Card

DEEP SEA control plate, DSE 7320 with grid monitor that starts-up the generator set when it detects a failure in the electrical power supply from the grid and sends a signal to the switching panel to switch from the grid position to the group position. Once the power supply has been re-established, it sends an order to the switching panel to transfer the generator set power to the grid and shuts-down the generator set once it has cooled down. It also starts-up the generator set using an external signal.

Also, control plate DSE 7320 checks a large number of parameters of the generator set which allows it to display information, statuses and alarms. If required, it will shutdown the generator set: Due to high coolant fluid temperature, low oil pressure, low coolant fluid level, etc.

Includes a 132x64 pixel LCD screen with lighting, 5 navigation menubuttons, independent operational mode buttons, and alarms and status indicating LEDs.

Communications via USB, RS232, RS485, as well as DSEnet® for system upgrade. Possibility of Ethernet connection (requires a separate module). MODBUS protocol available for client software. Completely configurable using a PC in Windows environment and free Scada type software in real time.

Includes reading and displaying of parameters with RMS values, real time clock, events history log up to 250 events and programming of alarms, events, start-ups and shutdowns.

Operating modes: START-UP, SHUTDOWN, AUTO, MANUAL AND TEST.

Generator

- Generator voltage (L-N)
- Generator voltage (L-L)
- Generator frequency
- Generator current
- kW
- kVA
- kWh
- kVAh
- Power factor

Grid

- Grid voltage (L-N)
- Grid voltage (L-L)
- Grid frequency

Engine

- Turn speed
- Cooling fluid temperature
- Oil pressure
- Hour meter
- Battery voltage
- No. of start-ups
- Fuel level

Protections

- Start-up fault (generator set shutdown)
- High coolant temperature (alarm and generator set shutdown)
- Low oil pressure (alarm and generator set shutdown)
- Low fuel level (alarm)
- Low cooling fluid level (generator set shutdown)
- Overload (alarm and generator set shutdown)
- Battery voltage high (alarm)
- Battery voltage low (alarm)
- Battery charge alternator failure (alarm)
- Generator low frequency (alarm and shutdown)
- Generator high frequency (alarm and shutdown)
- Generator low voltage (alarm and shutdown)
- Generator high voltage (alarm and shutdown)
- External emergency shutdown (shutdown)
- Engine overspeed (shutdown)
- Maintenance interval (alarm)



■ ATS

Optional cabinet for switching between the grid and the generator set by means of a Socomec brand motorized switch with an integrated mechanical and electrical interlocking device.

Allows for the padlock locking function. Includes a Manual / Automatic mode selector and emergency manual control.

Safety switching for isolating the loads. High dynamic resistance against short-circuits.

Position indicator with fully visualized cut-off. Stable positions not affected by changes in voltage and mechanical vibrations. External electrical control of the positions and test sequences.

High number of operations. IP54 protection. Connections: Lower/lower.

ATS	4P 1000A 160-333V L-N CCM
------------	---------------------------

■ DIMENSIONS AND WEIGHT

Length, L (mm)	3.325
Width, A (mm)	1.800
Height, H (mm)	2.315
Weight (kg)	4.155

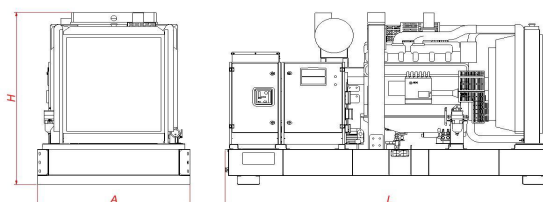

■ PERFORMANCE CLASS

Execution class in accordance with ISO 8528/5 (2005) taking into account the behaviour of the generator set in a permanent mode of operation with different load levels, as well as in a temporary mode of operation due to shocks in the load.

Performance class	G2
--------------------------	----

■ REGULATION

The generator set has a CE Marking that includes the following directives:

- 2006/42/CE Machine Safety.
- 2006/95/CEE Low Voltage.
- 2004/108/CE Electromagnetic compatibility.
- 97/68/CE Gases and contaminating particles emissions.
- 2005/88/CE Noise emissions of machines outdoors in soundproof generator sets.

Applicable international regulations:

- ISO 8528
- ISO 3046
- BS 5000
- IEC 60034

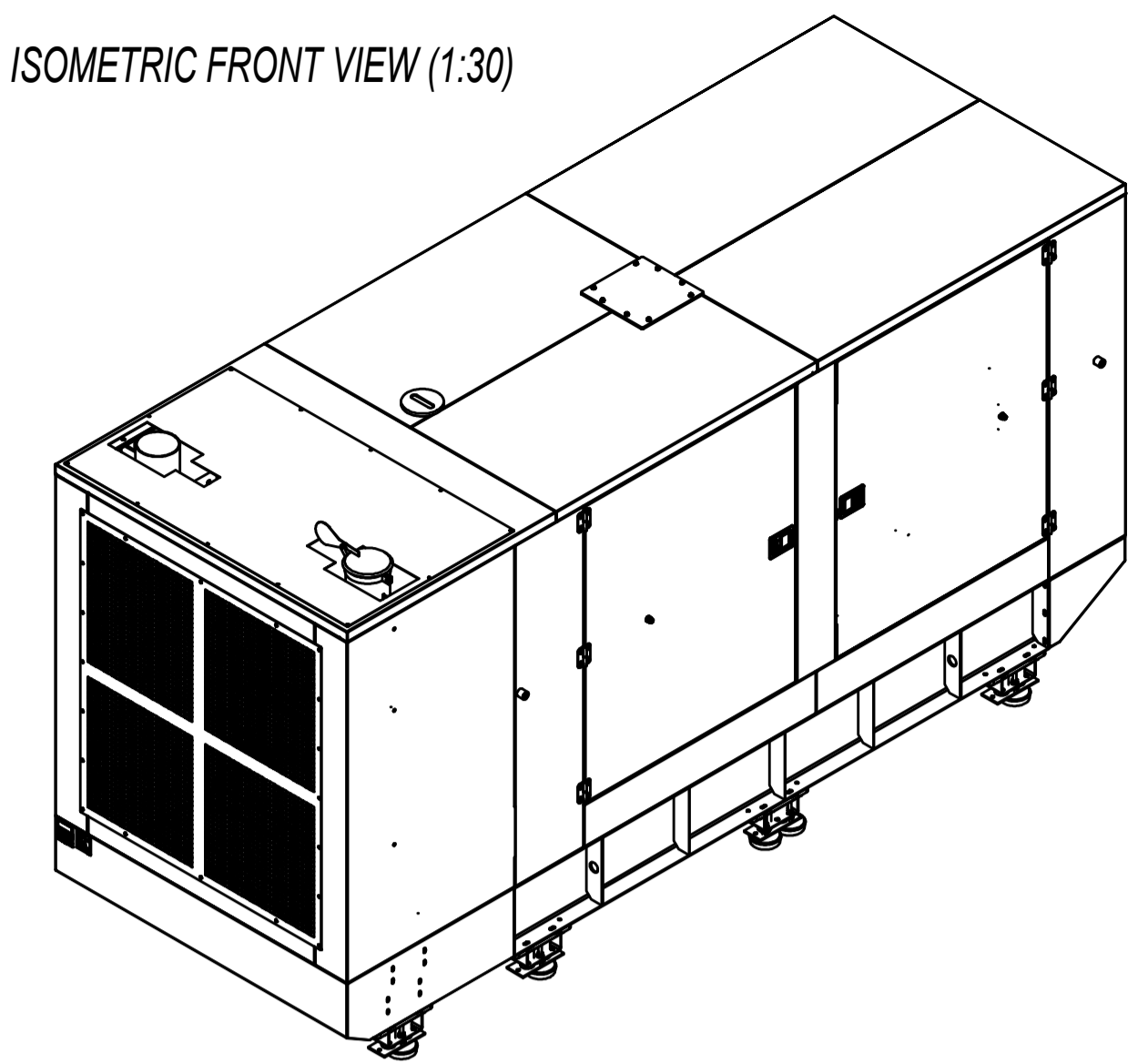
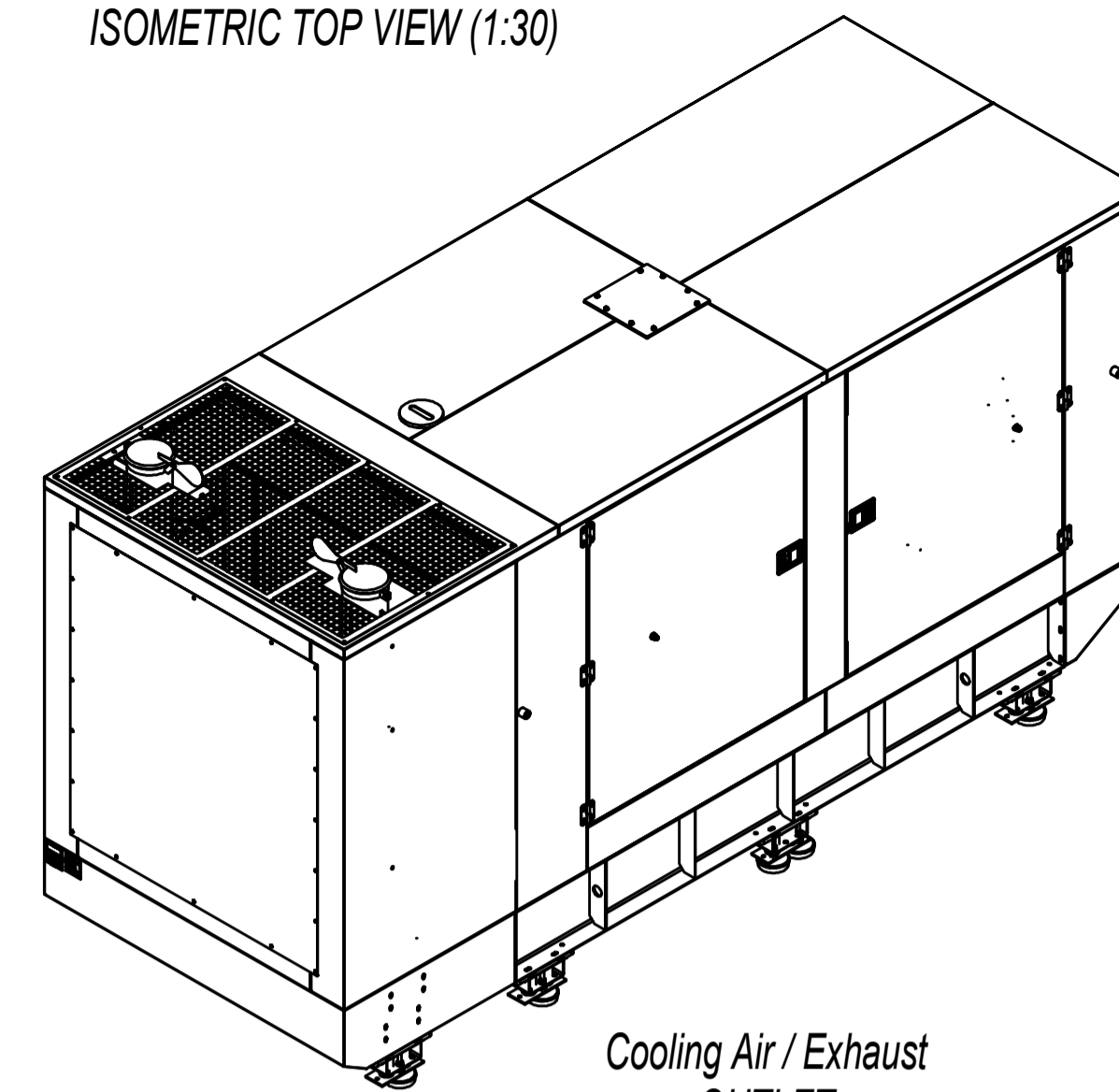
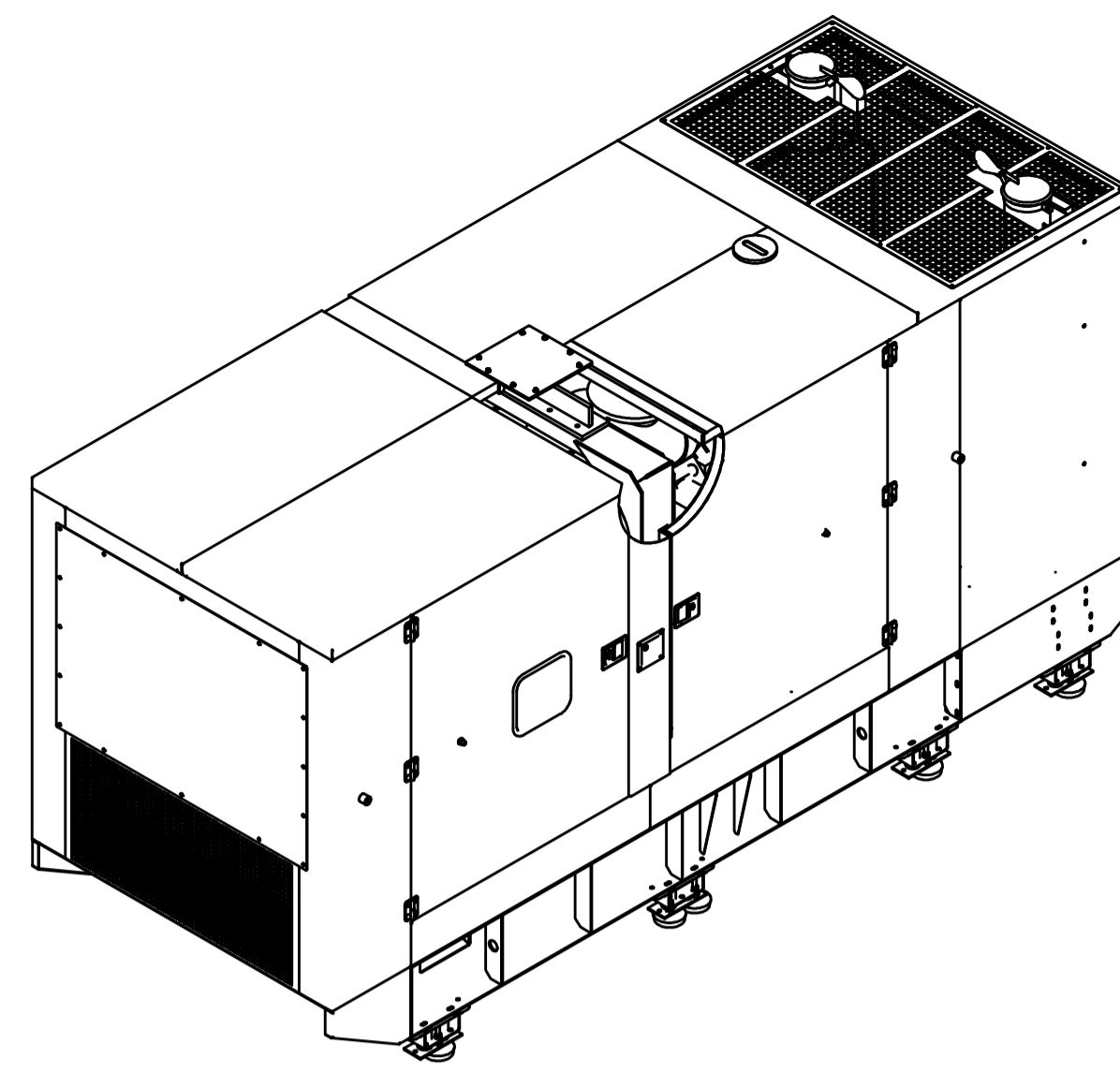
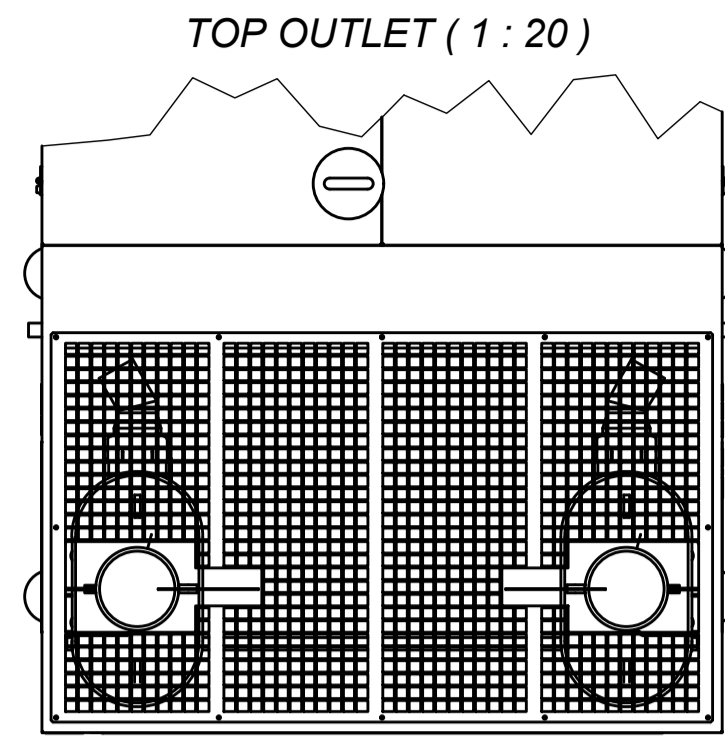
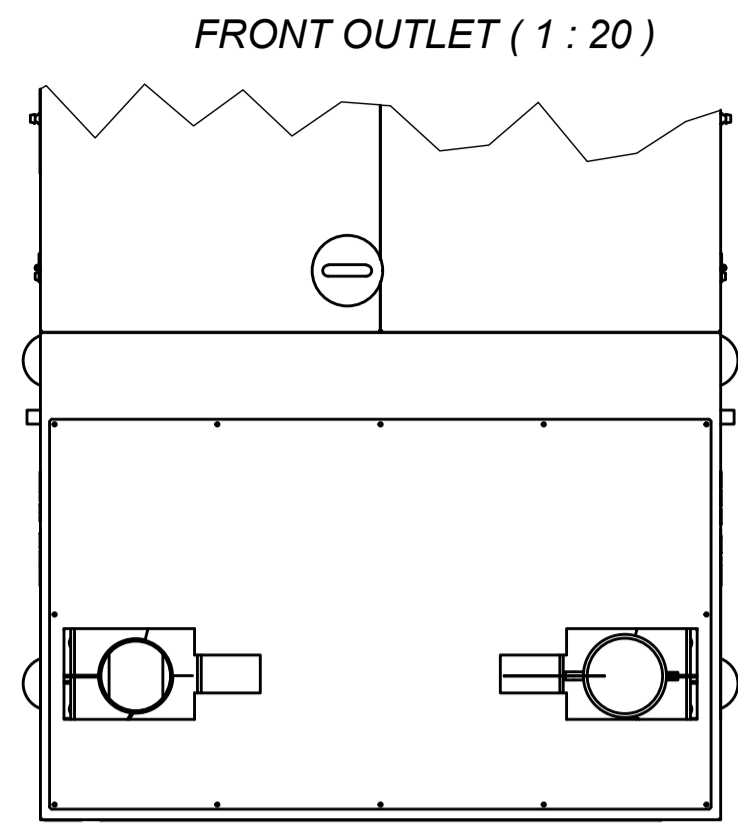

Cooling Air / Exhaust
OUTLET
↑↑↑↑

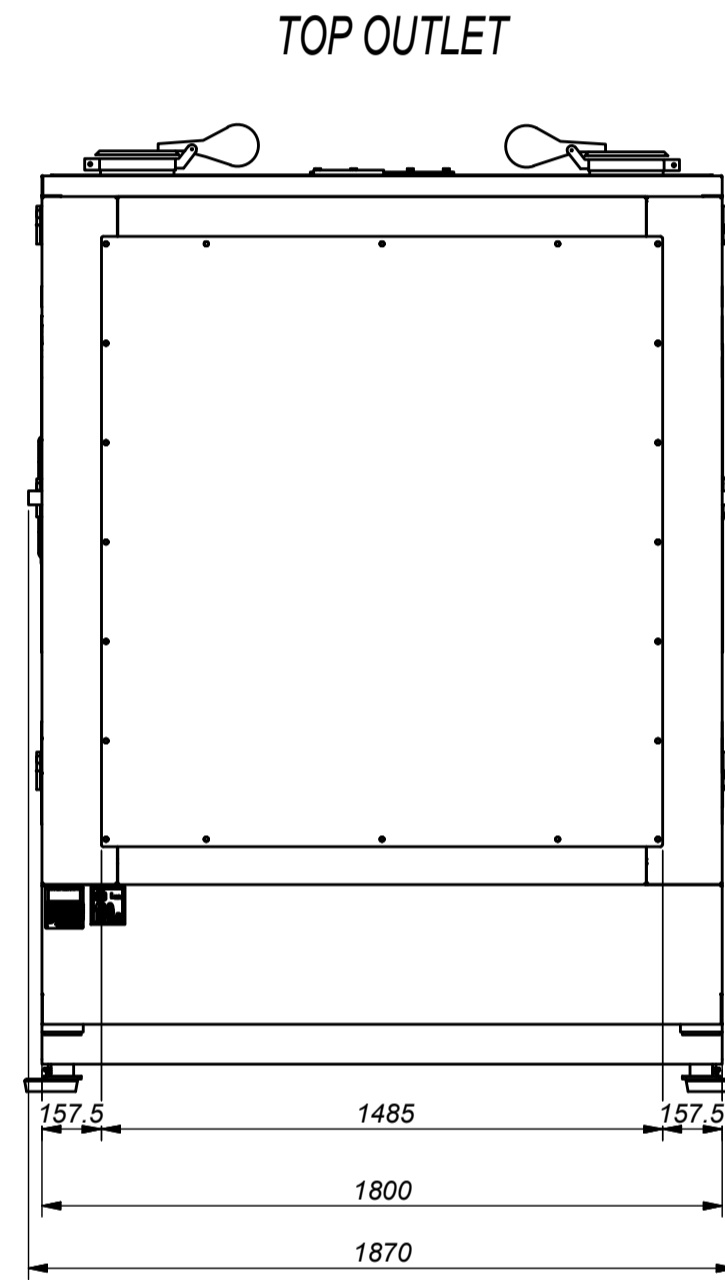
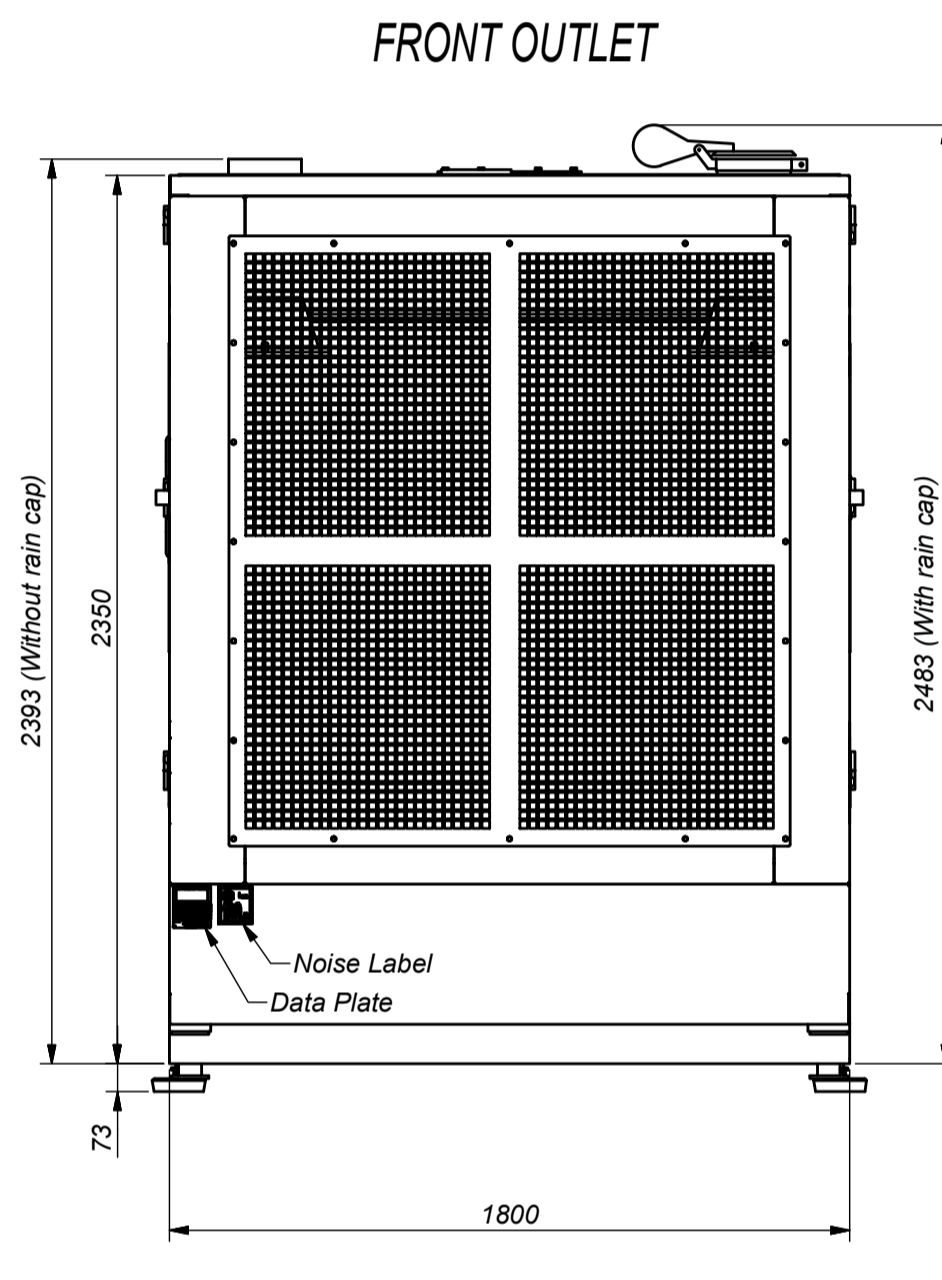

Cooling
Air Inlet
↑↑↑↑

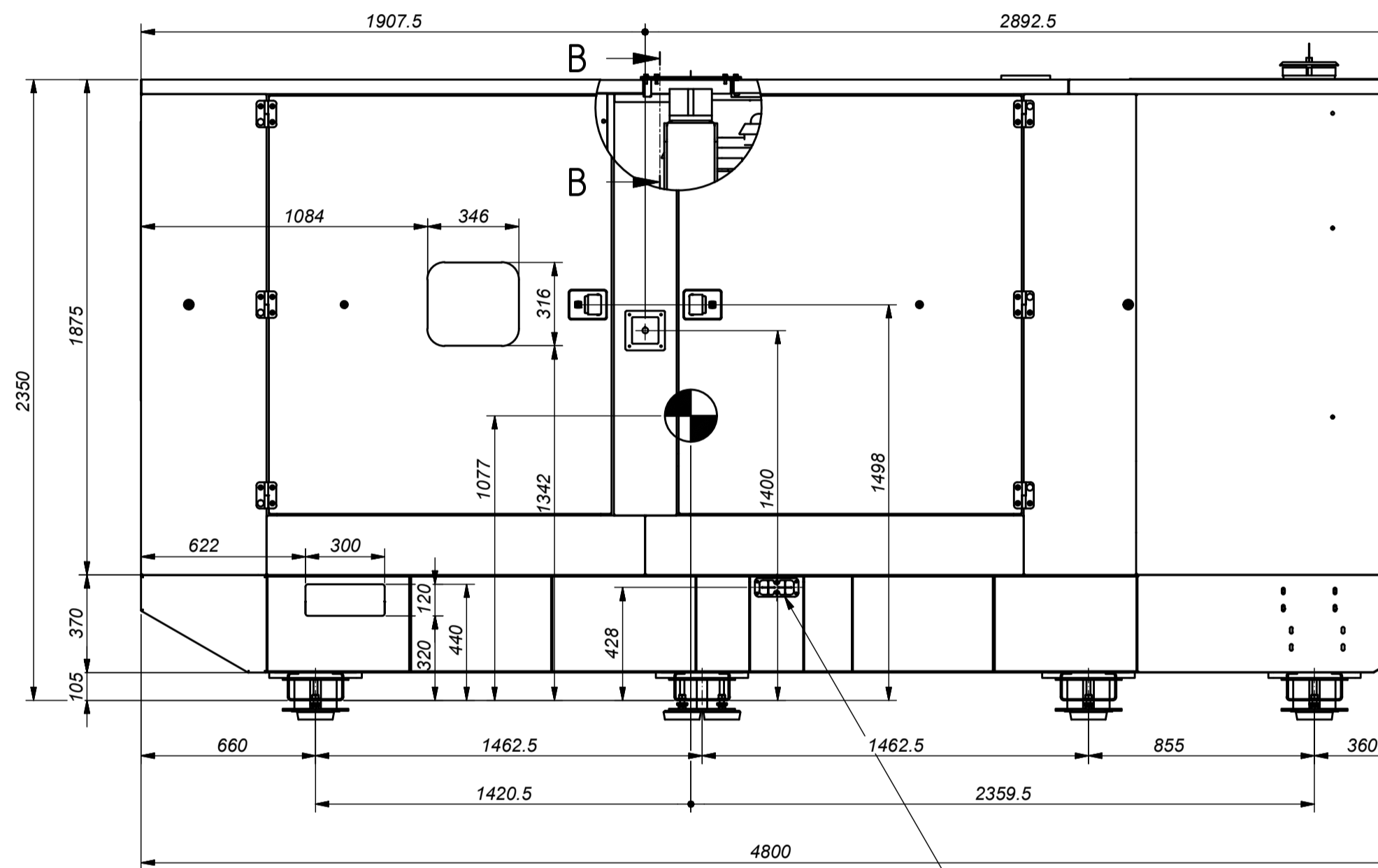

External Fuel Tank
connections (EFT)

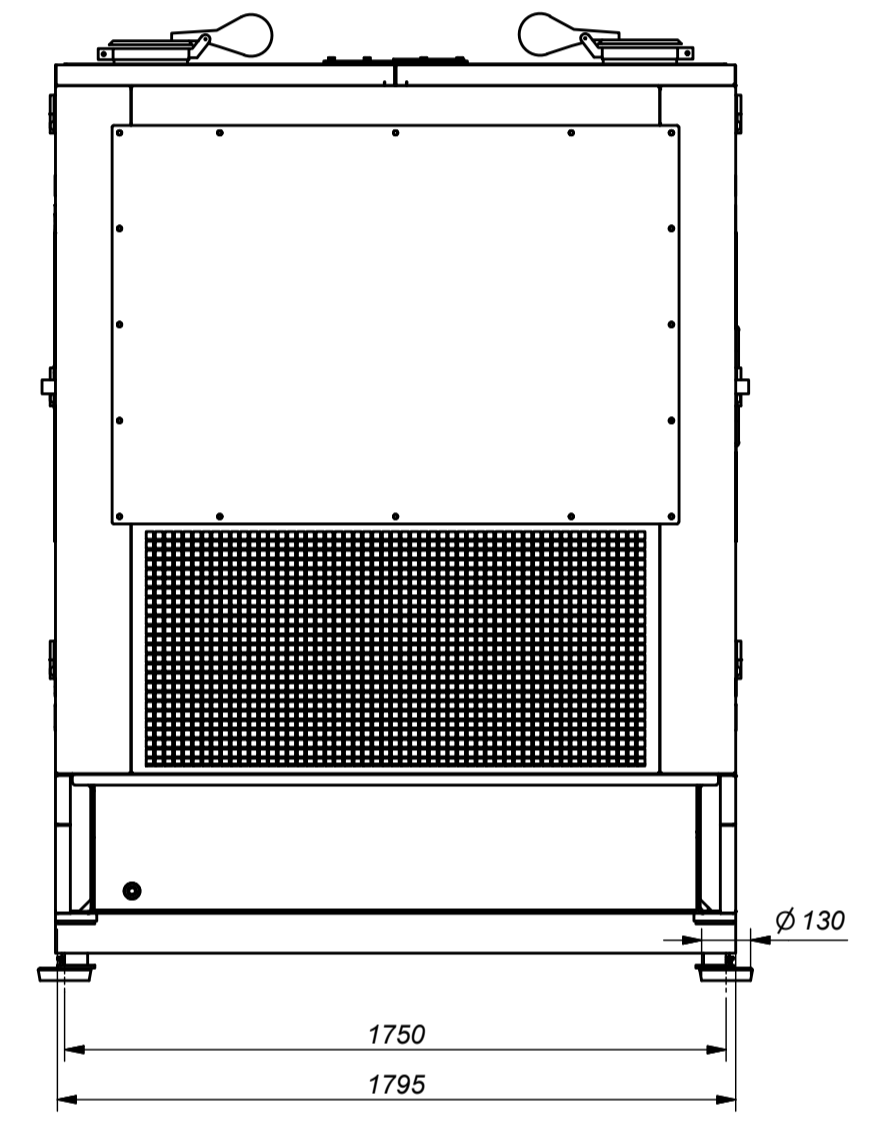

MAINTENANCE SPACE (1:30)

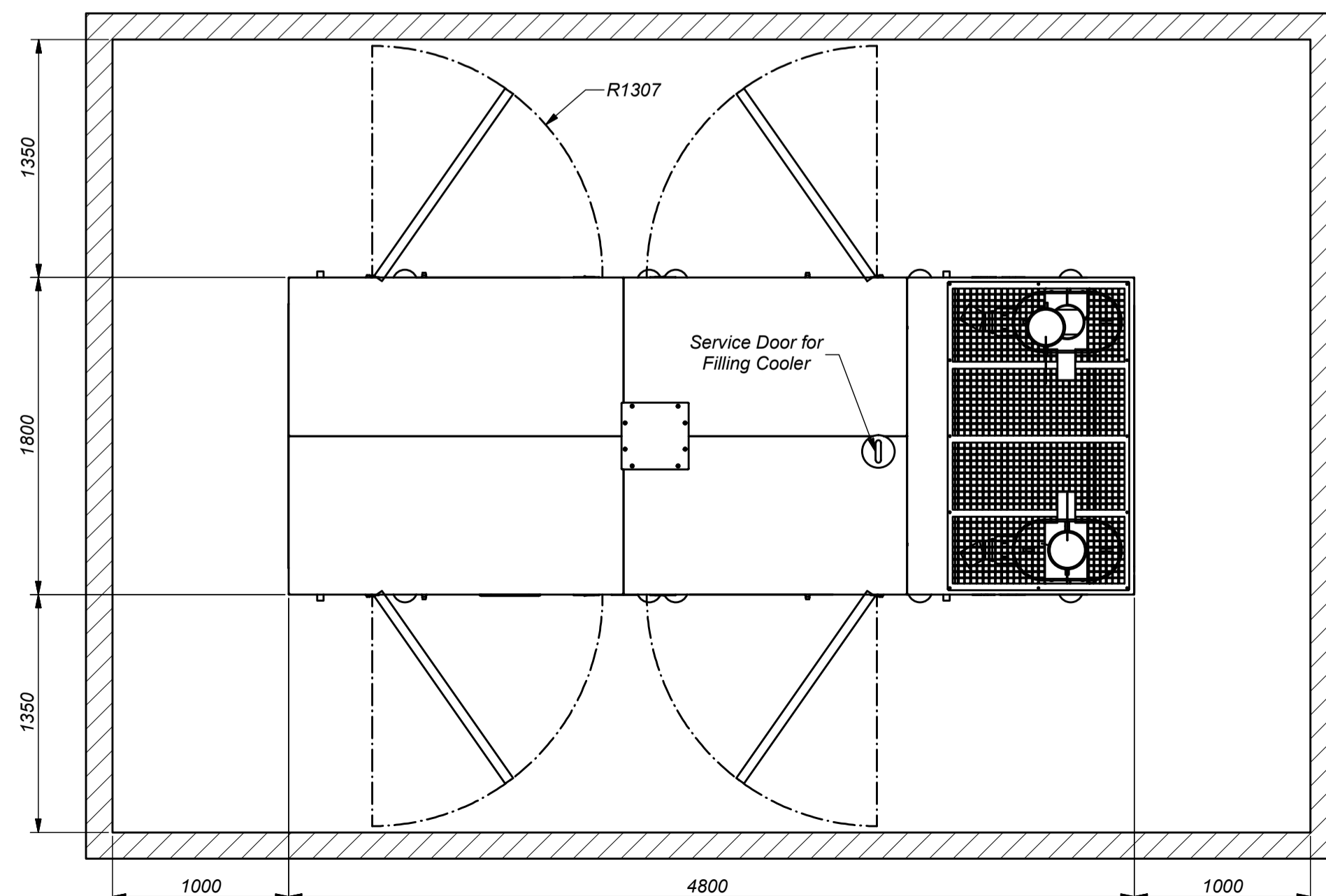

Cooling
Air Inlet
↑↑↑↑

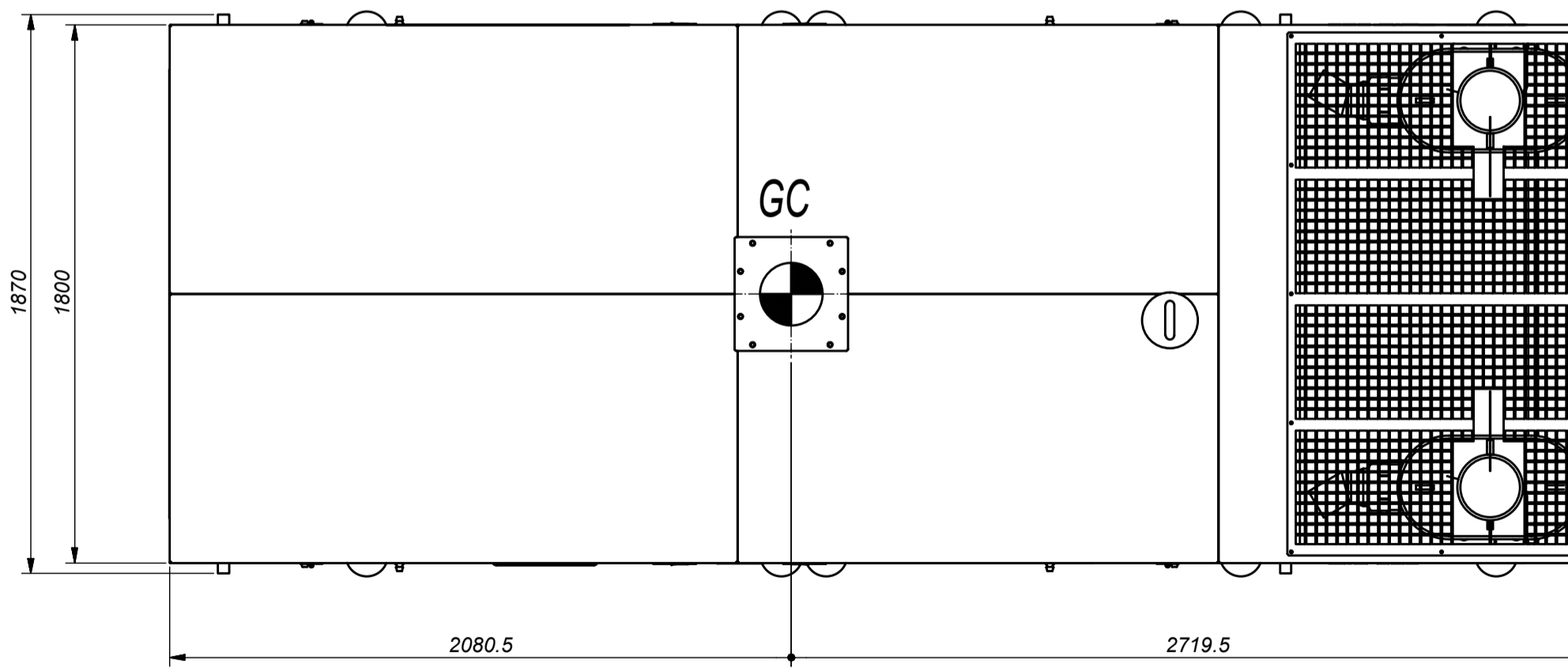

ALIGN CUBICLES WITH CUBICLE SUPPORT

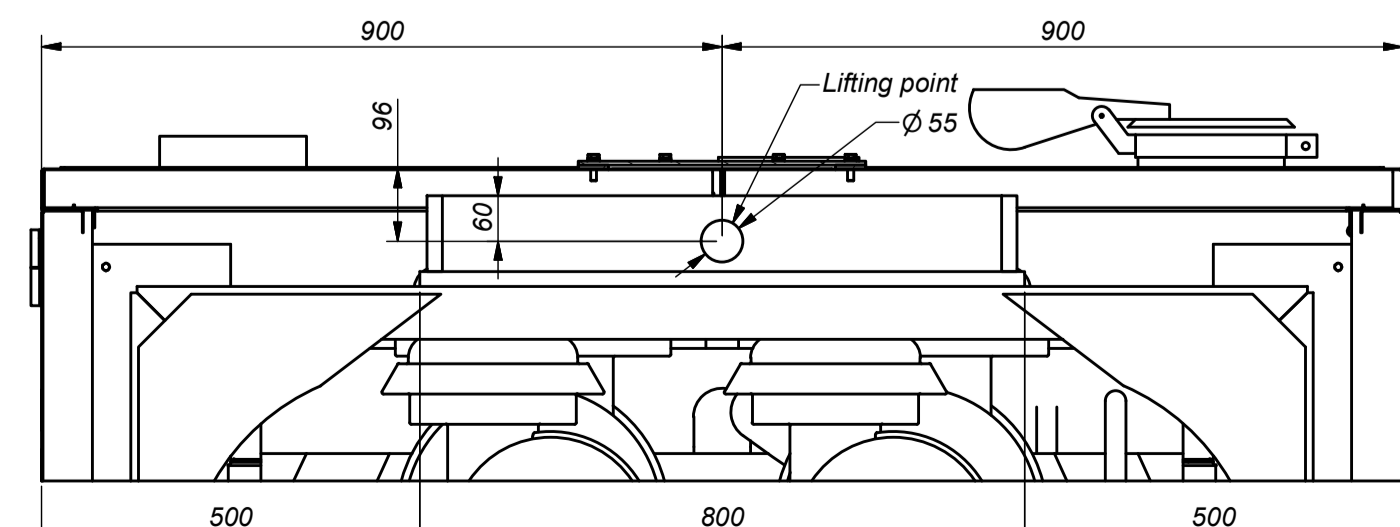

B-B (1:10)

MODEL TABLE			
(50 HZ) KVA	(60 HZ) KVA	(50 HZ) KW	(60 HZ) KW
470	400	410	380
510	450	460	420
580	500	525	455
630	540	570	510
700	610	635	550

TOTAL APPROX. WEIGHT with empty tank = 4665 kg
Capacity tank : 896 ltrs

All materials supplied are in compliance with the requirements of the List of Prohibited Substances

Name		DIMENSION DRWG		MODEL (SEE DRAWING)		Confidentiality Class	
Material						Confidential	
Treatment						Thickness:	INV
Scale	Family	A1		Compare		Drawing owner	
Drawn by	Blank nr.	Replaces				ESF	
Version Drwg	Blank wt	Kg		Fini wt.		Designation	
00	00	13409,73		Kg		Date	
00	00	03/02/2014		1633026381		Sheet 1 / 5	

3802432	03
Parent 3D model	Ed - Version 3D

CONFIDENTIAL: This document is our property and shall not be distributed or used without our prior permission. All rights reserved. For use only for manufacturing or communication to our clients or suppliers.

00	Position	Modified from	09/12/2014	jamiguel
Ed			Date	Intr./Appr.

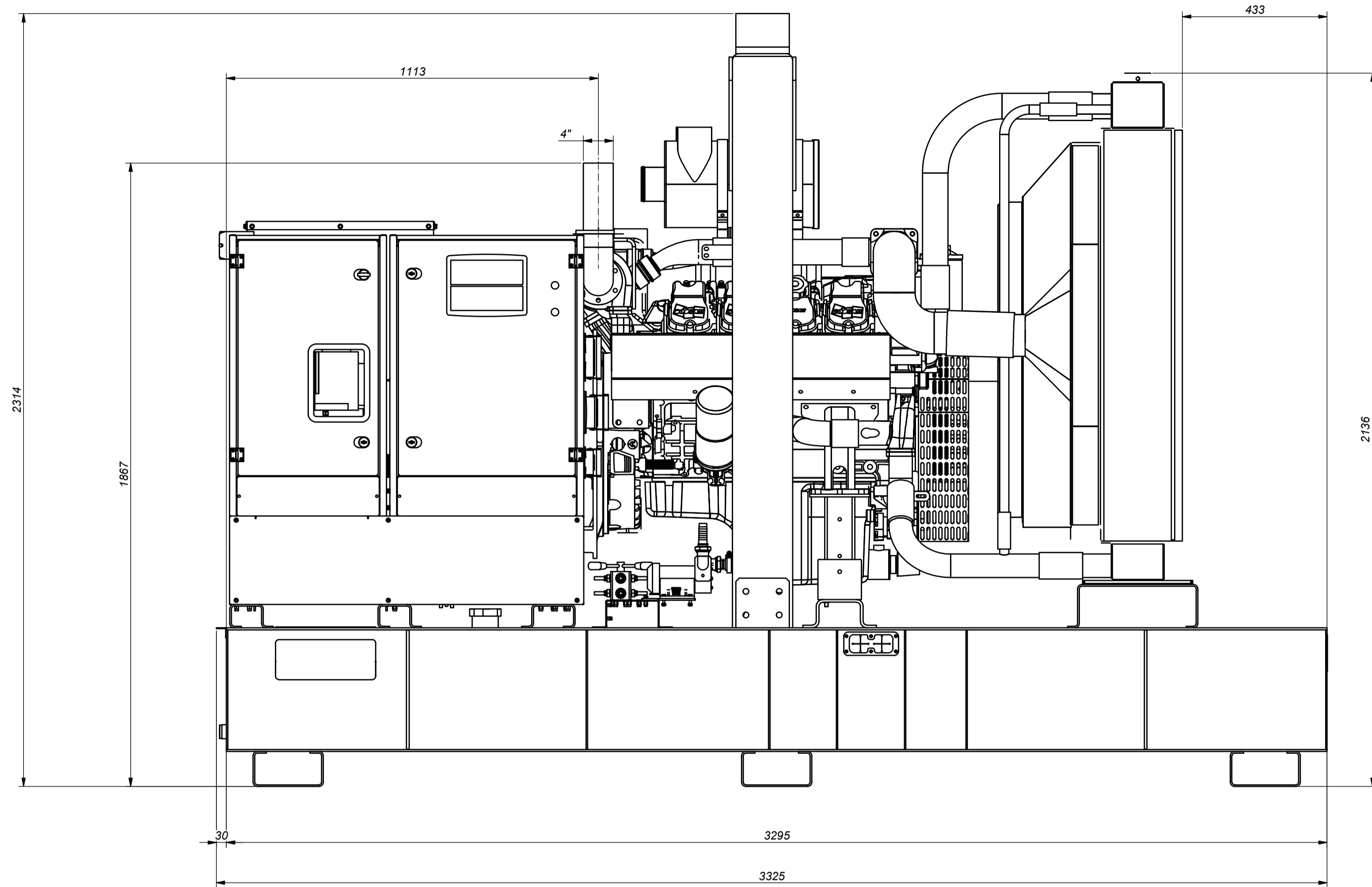

ENGINE P158 (1 : 10)

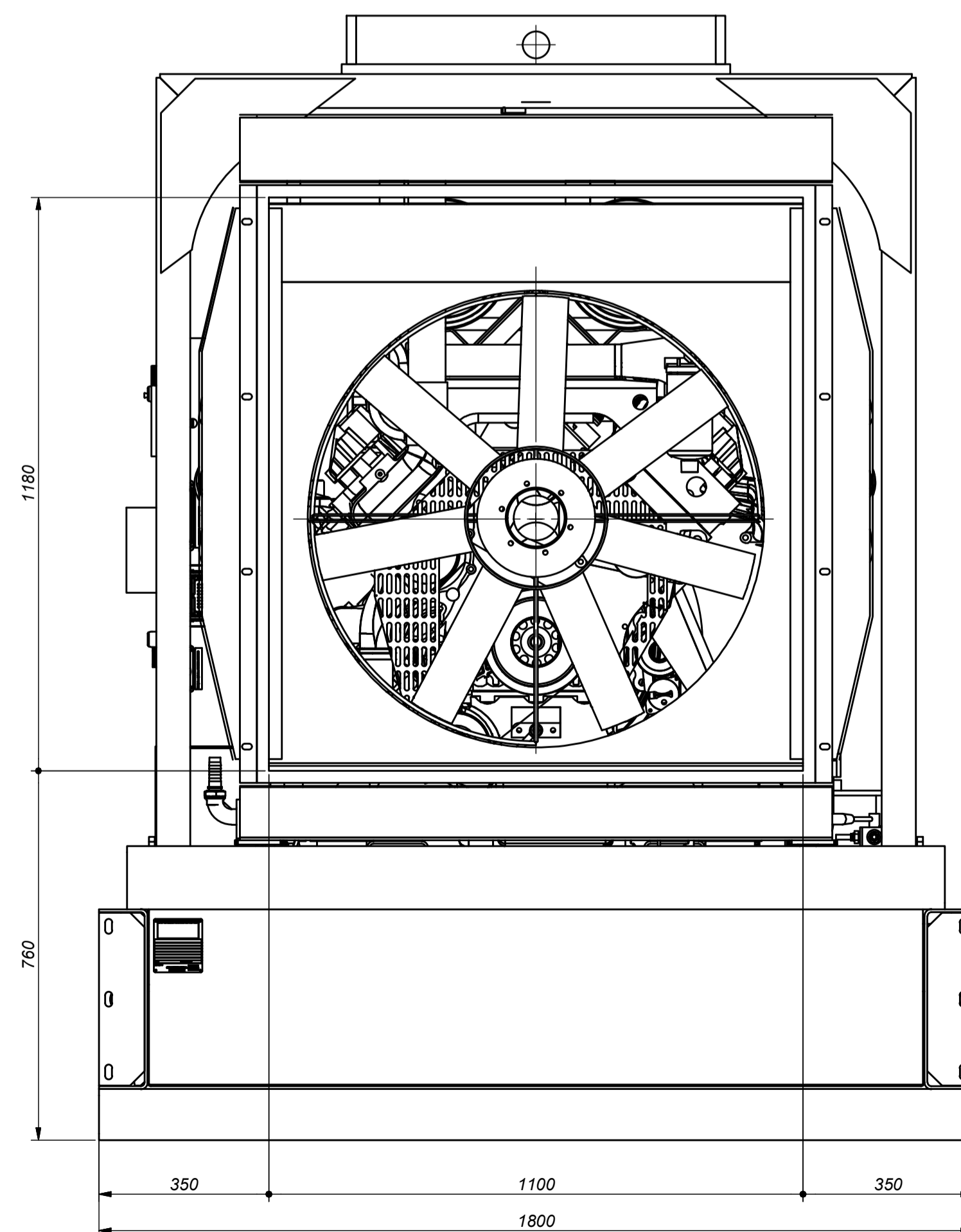
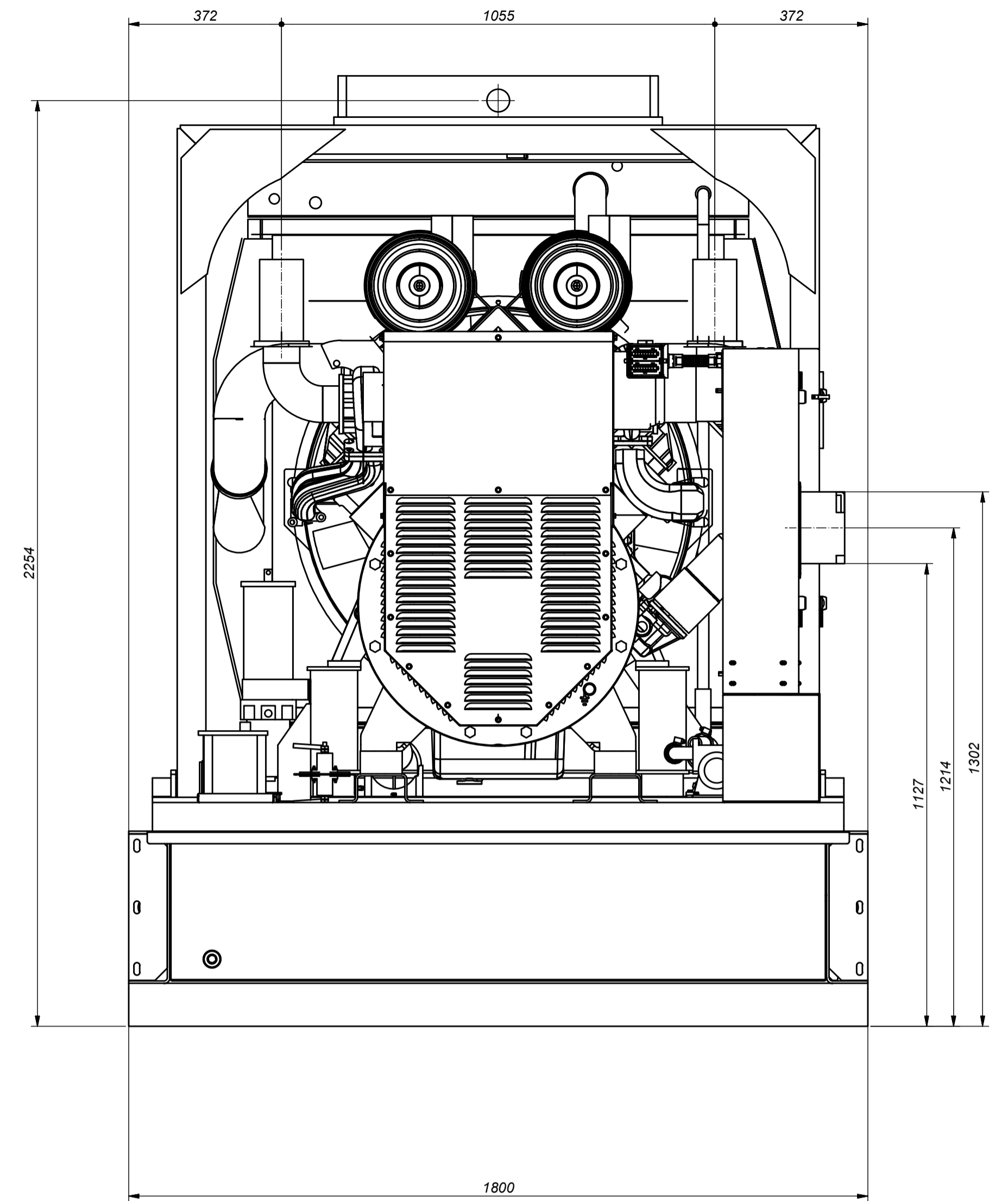

A (1 : 10)

TOTAL APPROX. WEIGHT with empty tank = 3625 kg
Capacity tank : 896 ltrs

Tolerances, if not indicated, according to:

Name		DIMENSION DRWG		MODEL (SEE DRAWING)		Confidentiality Class	
Material						Confidential	
Treatment						Thickness:	INV
Scale		Family		A1		Compare	
Drawn by magil		Blank nr.				Replaces	
Version Drwg		Blank wt		Kg		Designation	
00		00		13409,73		1633026381	
STATUS		Des checked.		Prod checked.		Approved.	
03		03		03/02/2014		Date	

3802432	03
Parent 3D model	Ed - Version 3D

CONFIDENTIAL: This document is our property and shall not be disclosed without our prior permission. It is intended for use only for the project for which it was prepared and shall not be used for any other project or company.

00	Position	Modified from	09/12/2014	jamiguel
Ed		Date	Intr./Appd.	

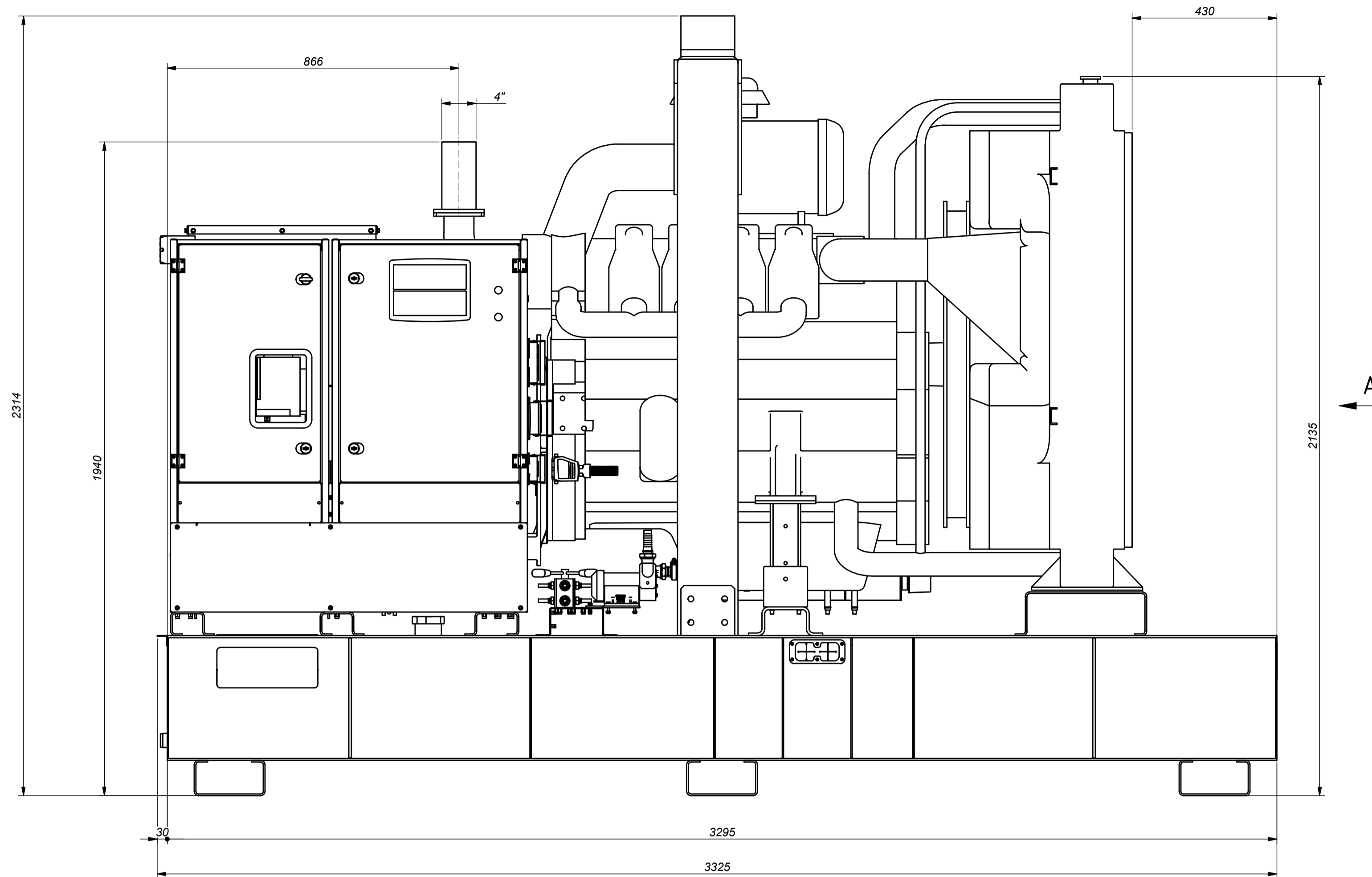

ENGINE DP158 (1 : 10)

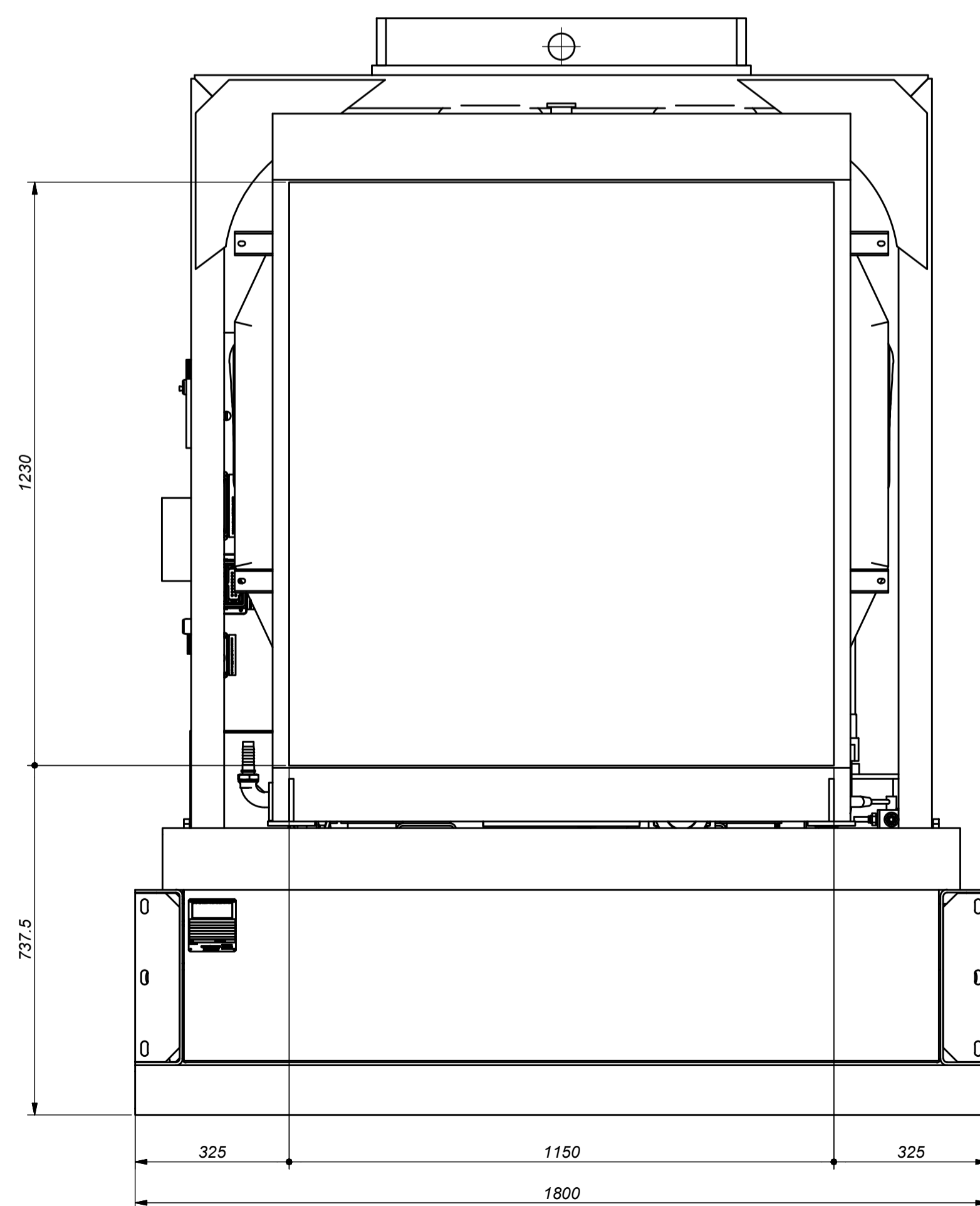
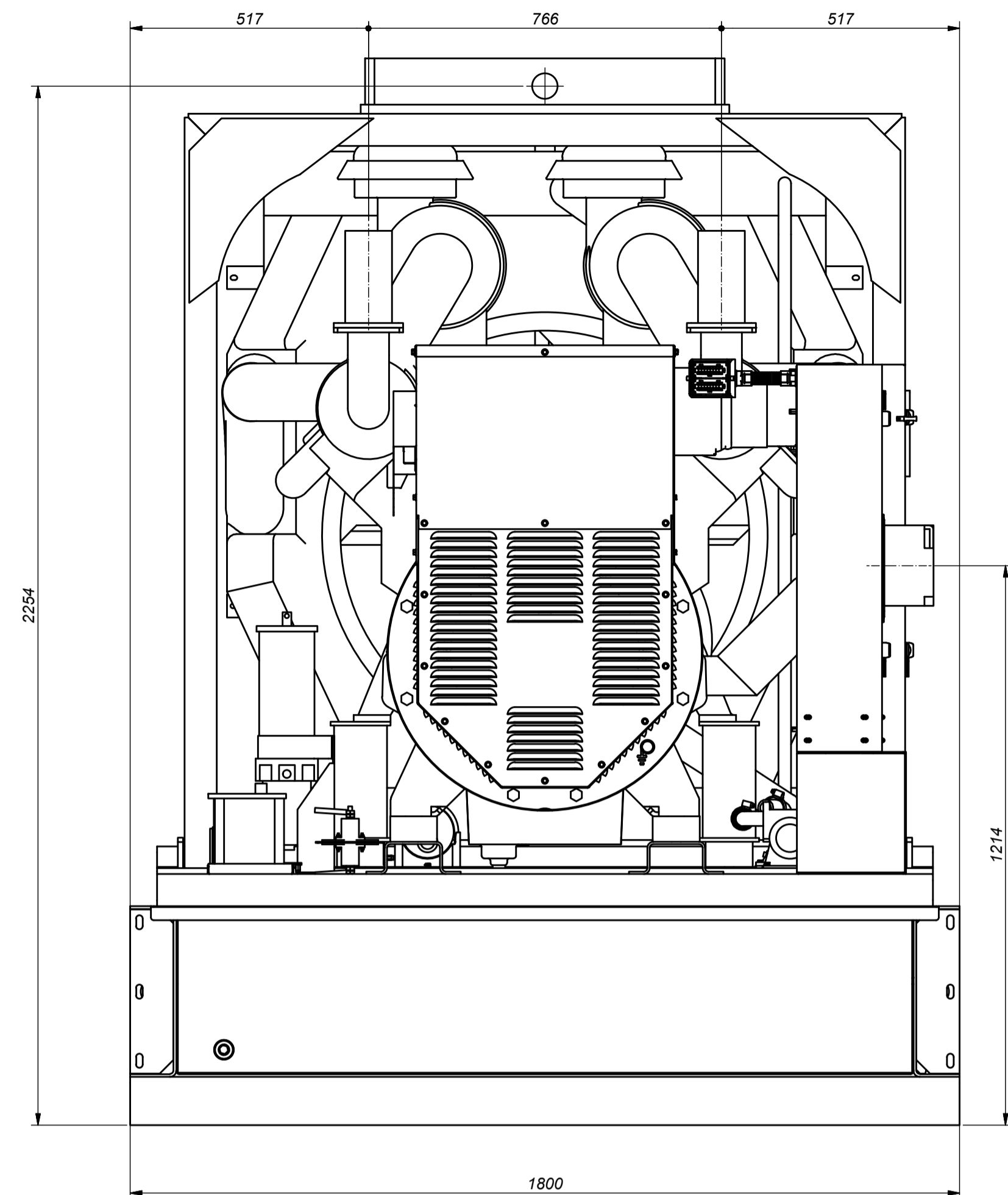

A (1 : 10)

Tolerances, if not indicated, according to:									
Name		DIMENSION DRWG			MODEL (SEE DRAWING)			Confidentiality Class acc. to 1102 K	
Material								Confidential	
Treatment								Thickness: INV	
Scale		Family			A1			Compare	
Drawn by		magil			Blank nr.			Replaces	
Version Drwg		Blank wt			Kg			Fini wt. 13409,73 Kg	
STATUS		Des checked.			Prod checked.			Approved.	
Date		03/02/2014			Designation			1633026381	
Parent 3D model		Ed - Version 3D			Approved			Sheet 3 / 5	

CONFIDENTIAL: This document is our property and shall not be disclosed without our prior permission. It is intended for manufacturing or communication to our client or partner.

00	Ed	Position	Modified from	Date	Intr./Appd.
				09/12/2014	jamiguel

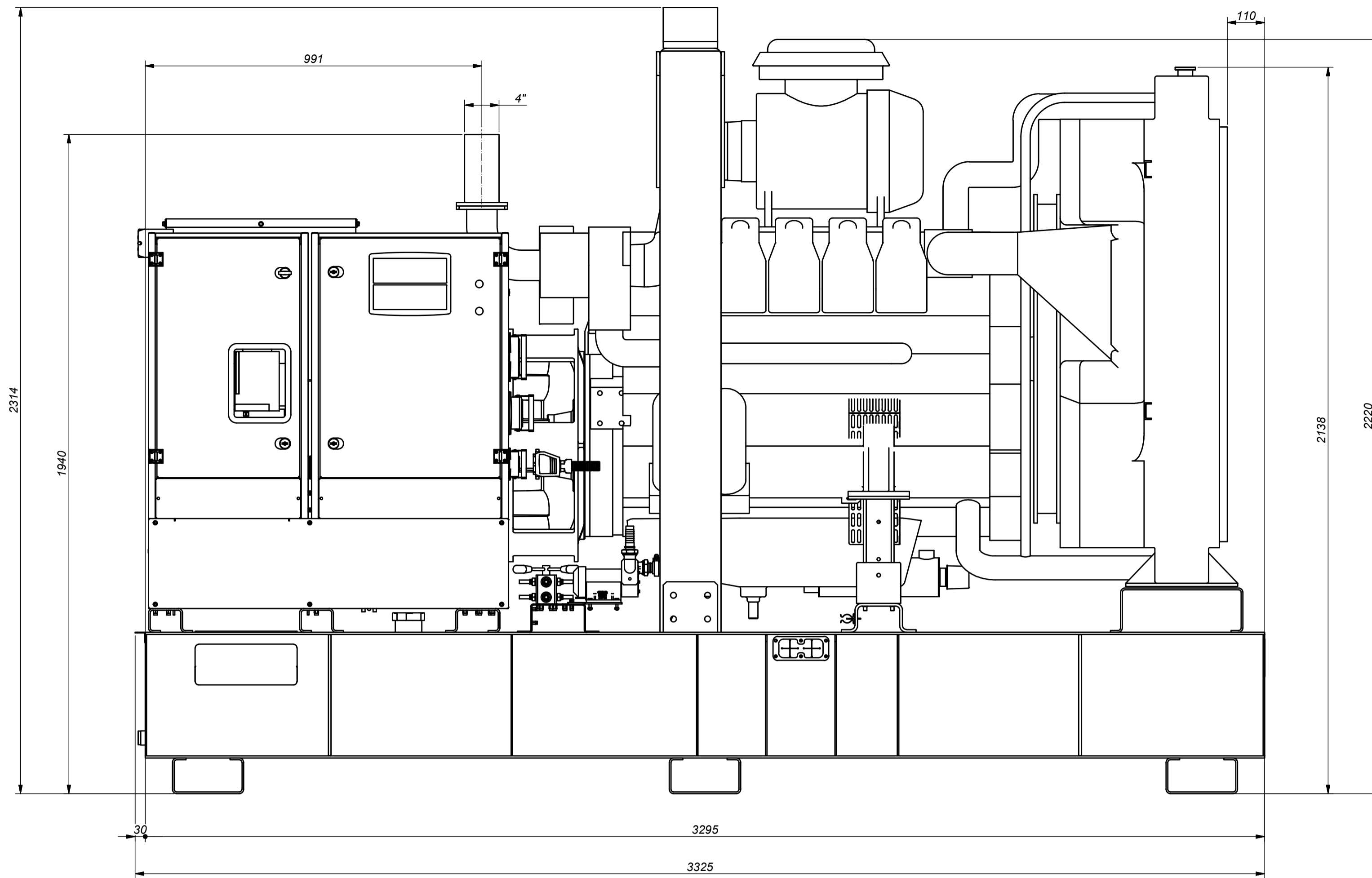

ENGINE DP180 (1 : 10)

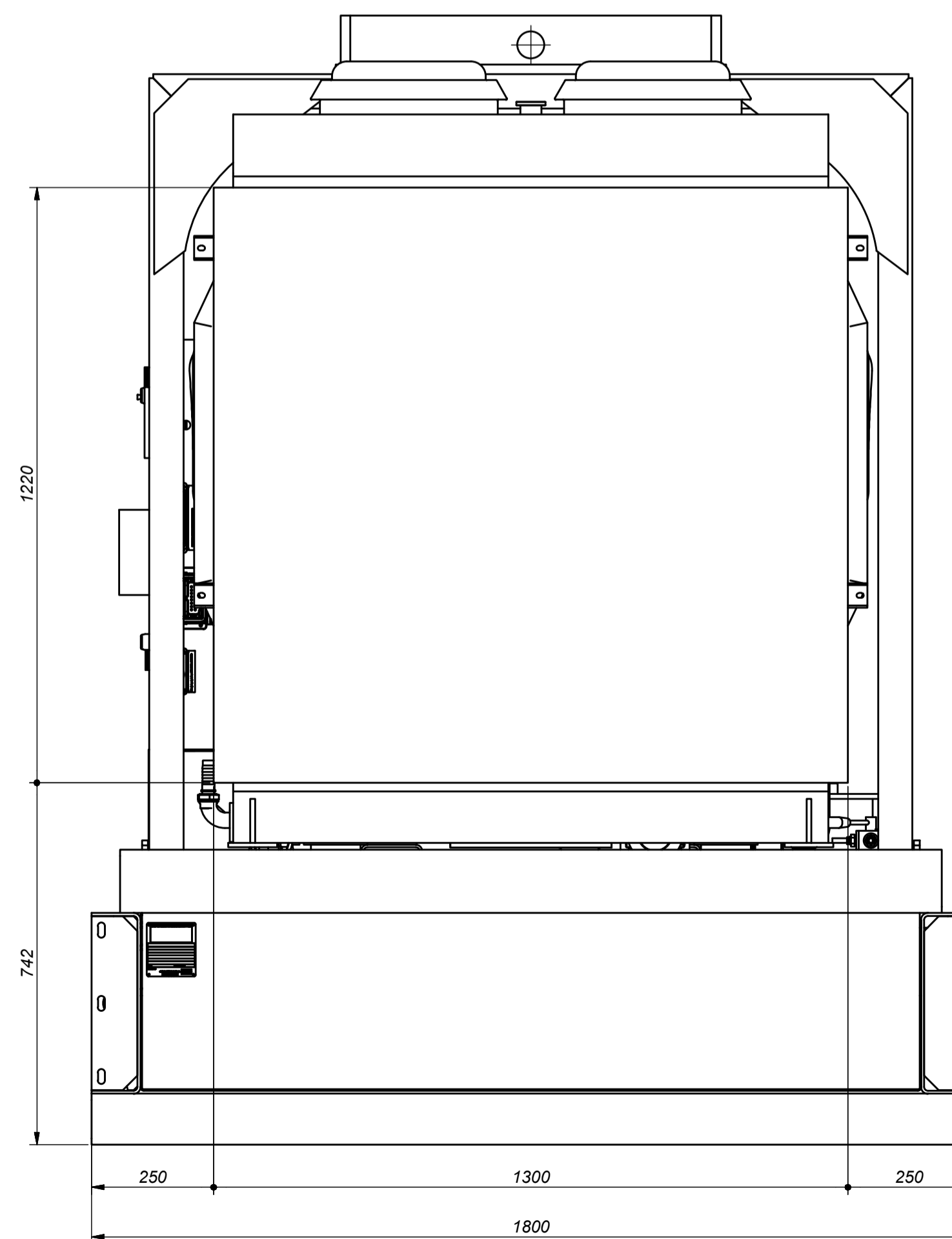
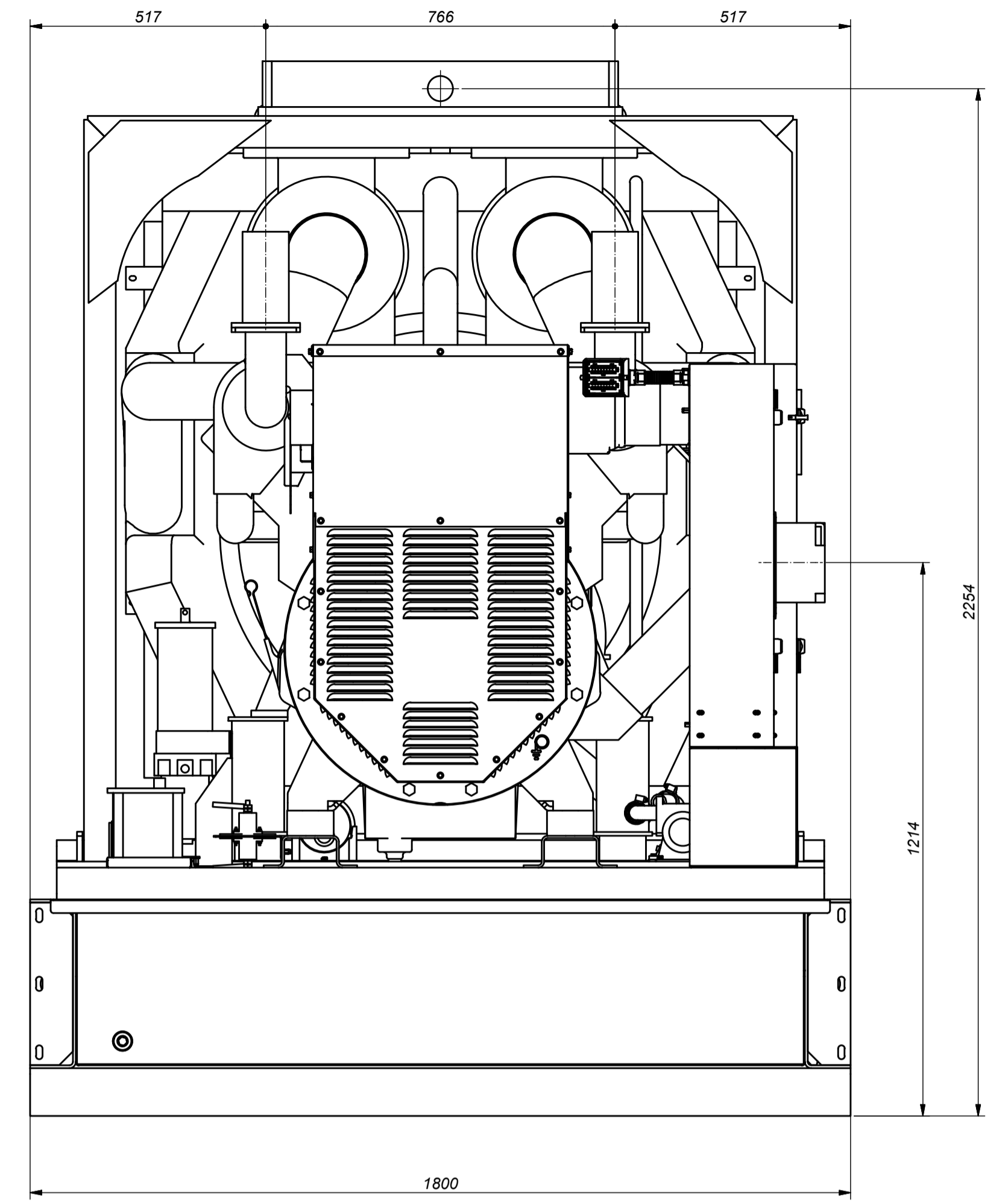

A (1 : 10)

Tolerances, if not indicated, according to:									
Name		DIMENSION DRWG			MODEL (SEE DRAWING)			Confidentiality Class acc. to 1102 K	
Material								Confidential	
Treatment								Thickness: INV	
Scale		Family			A1			Compare	
Drawn by		magil			Blank nr.			Replaces	
Version Drwg		00			Blank wt			Kg	
STATUS		Approved			Des checked.			Prod checked.	
Parent 3D model		Ed - Version 3D			Fini wt.			13409,73 Kg	
Date		03/02/2014			Designation			1633026381	
Drawing owner		ESF			Sheet			4 / 5	

3802432	03
Parent 3D model	Ed - Version 3D

CONFIDENTIAL: This document is our property and shall not be disclosed without our prior permission. It is intended for manufacturing or communication to our client or company.

00	Position	Modified from	09/12/2014	jamiguel
Ed		Date	Intr./Appd.	

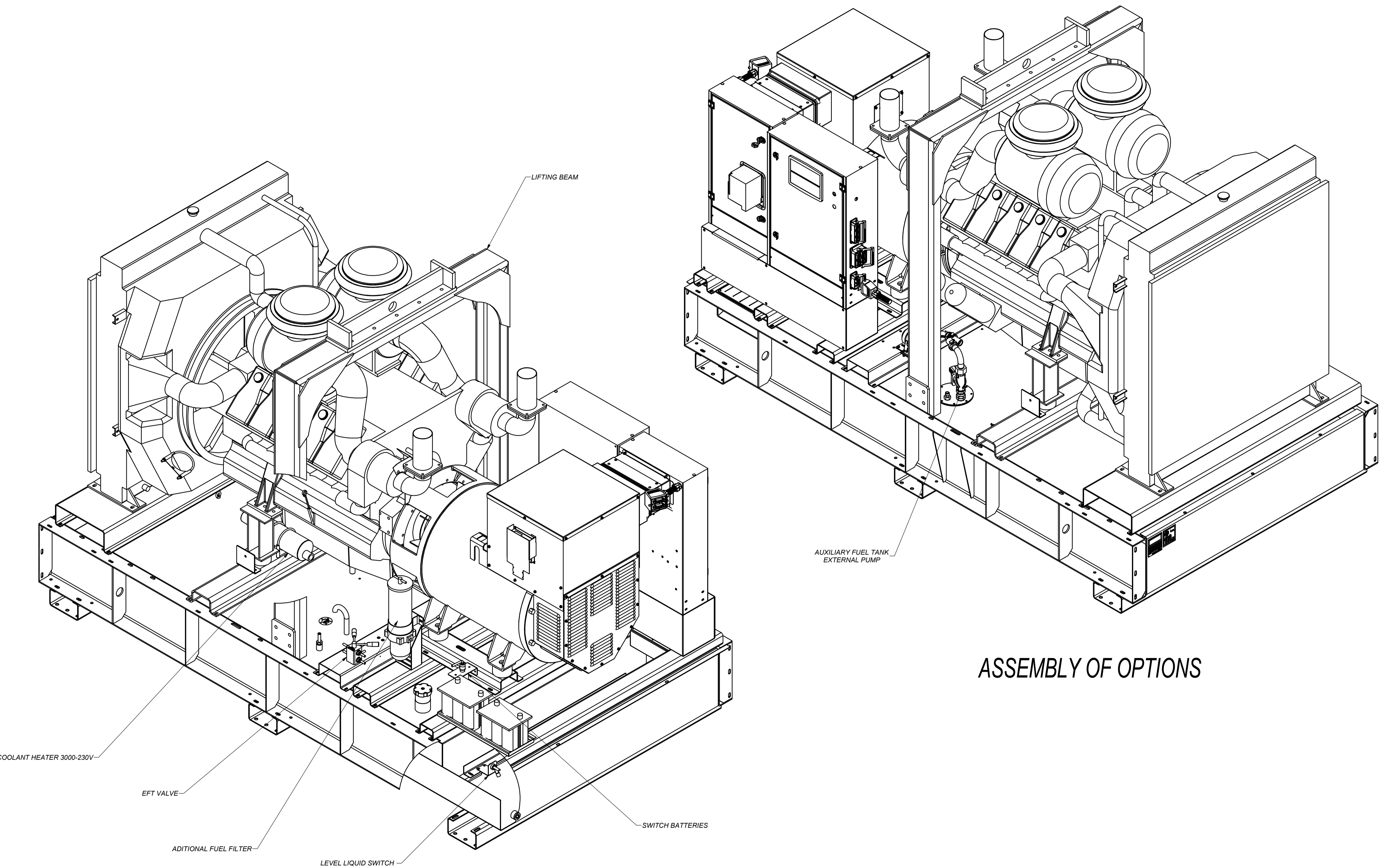

ASSEMBLY OF OPTIONS

All materials supplied are in compliance with the requirements of the List of Prohibited Substances

Tolerances, if not indicated, according to:		General tolerances			
		1350K - mK			
Name			DIMENSION DRWG MODEL (SEE DRAWING)		
Material			Confidential		
Treatment			INV		
Scale	Family	A1		Compare	
Drawn by magil	Blank nr.	Replaces		Drawing owner	
Version Drwg	Blank wt	Kg		ESF	
00				Designation	
STATUS	Des checked.	Prod checked.	Approved.	Date	03/02/2014
3802432	03			13409,73 Kg	
Parent 3D model	Ed - Version 3D	Approved		1633026381	

CONFIDENTIAL: This document is our property and shall not be disclosed or used for any purpose without our prior permission. All rights reserved. No part of this document may be reproduced or transmitted in any form or by any means, electronic or mechanical, including photocopying, recording, or by any information storage and retrieval system, without our prior permission.

00	Position	Modified from	Date	Intr./Appd.
			09/12/2014	jamiguel