

Technical specifications

QI 735

Voltage: 400/230 V

Frequency: 50HZ



Genset Image for illustration purposes only

TECHNICAL INFORMATION

Standby Power (ESP)	kVA	735
	kW	588
Prime Power (PRP)	kVA	680
	kW	544
Mechanical structure	Open skid on baseframe	
Engine	DOOSAN DP222 LB	
Alternator	MECC ALTE ECO40-2L	
Control card	DEEP SEA 7320	
Measures (L x W x H)	mm	3.645 x 1.800 x 2.450
Empty weight	kg	4.841
Fuel tank	L	1.293

Voltages	Prime Power (PRP)		Standby Power (ESP)	
	(kVA)	(kW)	(kVA)	(kW)
380/220	680	544	735	588
400/230	680	544	735	588
415/240	680	544	735	588

Notes:

PRIME POWER: Electrical power data available at a variable load without limits of hours per year. An overload of 10 % is allowed for 1 hour of every 12. In accordance with ISO 8528/1 (2005) – PRP

STANDBY POWER: Electrical power data at variable load in an emergency in accordance with standard ISO 8528/1 (2005) – ESP. Overloads of emergency power are not allowed.

The standard reference conditions are: 25 °C, 100 kPa and 30% relative humidity. Gasoil density: 0.85 g/cm3. Gasoline density: 0.68 g/cm3.

■ INDEX

General description
Engine
Alternator
Bedplate
Electric Panel
ATS
Dimensions and Weight
Performance class
Regulation
Annex: Drawings

Grupos Electrógenos Europa, S.A. is a certified company with ISO 9001, ISO 14001, OHSAS 18001 and PECAL

We reserves the right to modify any characteristic of their equipment without prior warning.

Photographs representing the product range, while able to include options.

Weight and dimensions of a standard generator set.

Non-contractual document

Central Offices:

Polígono Industrial Pitarco II; Parcela 20

50450 Muel (Zaragoza) Spain

Tel.: +34 976 14 54 32

Fax: +34 976 14 54 31

info@gesan.com

After-sales Department:

Customer service: +34 976 14 54 33

Spare parts: +34 976 14 54 34

GENERAL DESCRIPTION

Generator set for automatic operation due to a grid failure, including the electrical operations panel, installed on a bedplate. Start-up of the generator set will be carried out when a failure in the grid power supply is detected. Once the generator set has stabilized, a signal is sent to the switching panel to switch the grid position to generator set. When the grid power supply return is detected, a command is sent to the switching to switch to the generator set position of the grid. The generator set shuts-down after the applicable cooling period has elapsed.

ENGINE

Doosan diesel engine, with turbo, with direct injection and Electronic regulation of the engine.

Engine brand	DOOSAN	Bore (mm)	128
Model	DP222 LB	Stroke (mm)	142
R.P.M.	1.500	Compression ratio	15:1
Net power (kWm)	640	Type of regulation	Electronic
Fuel	Diesel	Europe exhaust emission	EU0
No. of cylinders	12 V (90°)	EPA exhaust emission	N/A
Engine Capacity (c.c.)	21.927		

Cooling System

Cooling of the sleeves using cooling fluid comprised of water and glycol at 50% in a closed circuit driven by the engine pump.

Engine driven exhaust fan, radiator and expansion tank; original from the engine manufacturer.

The circuit is completed with the cooling purge system towards the outside of the bedplate and protections of all running surfaces

Flow of air from fan (m³/min)	860	Coolant capacity (l)	114
Cooling type	Water	Design temperature radiator (°C)	52°C

Lubrication System

Gear pump lubrication system driven by the engine and with original engine manufacturer lubricant filtering system.

It is completed with the oil purge system towards the outside of the baseframe.

Oil capacity (l)	40	Medium oil consumption (% fuel consumption)	0,5
-------------------------	----	--	-----

Air intake system

Air intake system for combustion with filtering device and filter change indicator; originals from the engine manufacturer. Intake air cooling after the turbo by means of an air/air exchanger.

Intake air flow (m³/min)	42	Air inlet filter type	Medium
--	----	------------------------------	--------

Exhaust System

Interior and exterior aluminized steel exhaust silencer.

T^a gas emission (°C)	481	Gas flow (m3/min)	101
--	-----	--------------------------	-----

Start system

Start system that uses an electrical motor, battery, battery disconnecter and battery charge alternator that is driven by the engine itself. The start motor and the battery charge alternator are originals from the engine manufacturer.

Lead acid battery with Spiralcell® recombining technology, sealed structure to prevent leaks, maintenance free, large start-up capacity maintaining the voltage due to its low internal resistance and small volume thanks to its rolled plates design that guarantees it will withstand many discharges with large temperature changes.

Starter voltage system (V)	24	Battery type	2 x 12V 44Ah - 730A
-----------------------------------	----	---------------------	---------------------

Fuel supply system

Fuel intake system original from engine manufacturer with filter.

Fuel tank capacity (L)	1.293
-------------------------------	-------

Fuel consumption panel (range according to the standard configuration)

Load	Prime Power (PRP)		Standby Power (ESP)	
	(l/h)	Range (h)	(l/h)	Range (h)
25%	39	33	42	31
50%	73	17,8	78	16,5
75%	109	11,9	118	11
100%	147	8,8	159	8,1

ALTERNATOR

Mecc Alte alternator with 4 poles, with a lifetime lasting greased bearing, H class insulation, without brushes, 2/3 coil and AVR (Automatic Voltage Regulator)

Protection of all the windings by means of 2-part high quality polyester resin impregnation. The stator windings receive a double impregnation. Final finish with a coat of EG43 varnish.

Excitation system with MAUX auxiliary winding with overload capacity 3 times the nominal current for 20 s.

Joining of engine and alternator through flexible disc coupling.

Regulations:

- CEI 2-3
- IEC 34-1
- EN 60034-1
- VDE 0530
- BS 4999-5000
- CAN/CSA-C22.2 No14-68-No100-95
- ISO 8528:3

Low wave distribution:

- THC < 4%
- THD < 4%
- THF (IEC) < 2%
- TIF (NEMA) < 40

Incorporates electromagnetic emissions suppressor in accordance with standard VDE 0875, class K.

Brand	MECC ALTE	Voltage Stability	±1%
Model	ECO40-2L	Performance at 75% p.f. 0.8 (%)	95
Alternator Power (kVA)	735 / Standby (SB27)	Performance at 100% p.f. 0.8 (%)	95
Number of wires	12	Direct subtransient reactance X''d (%)	9,2
IP Alternator	IP 21	Subtransient time constant, T''d (ms)	19
Excitation system	MAUX	Zero sequence reactance, Xo (%)	2,4
AVR model	DSR	Short-circuit ratio, Kcc	0,4

▪ BEDPLATE

The engine-alternator set is coupled to the bedplate by means of anti-vibration shock mounts that absorb almost all the vibrations.

The fuel tank is integrated and joined to the bedplate using hardware, which allows disassembling it for maintenance or replacement. It has a drainage plug, wide cleaning cover and filler connection with plug.

Includes level sensor with low fuel alarm signal that indicates the amount of fuel available in the tank to the electrical panel.

▪ ELECTRIC PANEL

Electrical panel integrated in the generator set with digital control plate.

Has a single-pole circuit breaker, manually actuated, with thermal-magnetic protection against overloads and short-circuits.

Circuit Breaker rated current (A)	4P 1250A R	Battery charger	DSE 9255 - 24V 5A
--	------------	------------------------	-------------------

Has a DEEP SEA battery charge maintainer, designed to be permanently connected to the battery and maintains it charged to its maximum capacity.

Has no moving parts. The charger switches to floating mode when the charge is complete

Control Card

DEEP SEA control plate, DSE 7320 with grid monitor that starts-up the generator set when it detects a failure in the electrical power supply from the grid and sends a signal to the switching panel to switch from the grid position to the group position. Once the power supply has been re-established, it sends an order to the switching panel to transfer the generator set power to the grid and shuts-down the generator set once it has cooled down. It also starts-up the generator set using an external signal.

Also, control plate DSE 7320 checks a large number of parameters of the generator set which allows it to display information, statuses and alarms. If required, it will shutdown the generator set: Due to high coolant fluid temperature, low oil pressure, low coolant fluid level, etc.

Includes a 132x64 pixel LCD screen with lighting, 5 navigation menubuttons, independent operational mode buttons, and alarms and status indicating LEDs.

Communications via USB, RS232, RS485, as well as DSEnet® for system upgrade. Possibility of Ethernet connection (requires a separate module). MODBUS protocol available for client software. Completely configurable using a PC in Windows environment and free Scada type software in real time.

Includes reading and displaying of parameters with RMS values, real time clock, events history log up to 250 events and programming of alarms, events, start-ups and shutdowns.

Operating modes: START-UP, SHUTDOWN, AUTO, MANUAL AND TEST.

Generator

- Generator voltage (L-N)
- Generator voltage (L-L)
- Generator frequency
- Generator current
- kW
- kVA
- kWh
- kVAh
- Power factor

Grid

- Grid voltage (L-N)
- Grid voltage (L-L)
- Grid frequency

Engine

- Turn speed
- Cooling fluid temperature
- Oil pressure
- Hour meter
- Battery voltage
- No. of start-ups
- Fuel level

Protections

- Start-up fault (generator set shutdown)
- High coolant temperature (alarm and generator set shutdown)
- Low oil pressure (alarm and generator set shutdown)
- Low fuel level (alarm)
- Low cooling fluid level (generator set shutdown)
- Overload (alarm and generator set shutdown)
- Battery voltage high (alarm)
- Battery voltage low (alarm)
- Battery charge alternator failure (alarm)
- Generator low frequency (alarm and shutdown)
- Generator high frequency (alarm and shutdown)
- Generator low voltage (alarm and shutdown)
- Generator high voltage (alarm and shutdown)
- External emergency shutdown (shutdown)
- Engine overspeed (shutdown)
- Maintenance interval (alarm)



■ ATS

Optional cabinet for switching between the grid and the generator set by means of a Socomec brand motorized switch with an integrated mechanical and electrical interlocking device.

Allows for the padlock locking function. Includes a Manual / Automatic mode selector and emergency manual control.

Safety switching for isolating the loads. High dynamic resistance against short-circuits.

Position indicator with fully visualized cut-off. Stable positions not affected by changes in voltage and mechanical vibrations. External electrical control of the positions and test sequences.

High number of operations. IP54 protection. Connections: Lower/lower.

ATS	4P 1250A 160-333V L-N CCM
------------	---------------------------

■ DIMENSIONS AND WEIGHT

Length, L (mm)	3.645
Width, A (mm)	1.800
Height, H (mm)	2.450
Weight (kg)	4.841

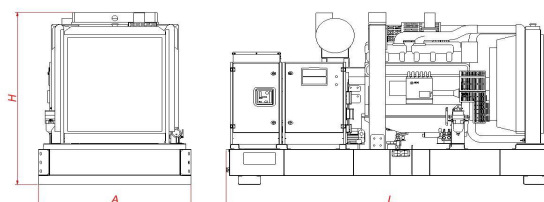

■ PERFORMANCE CLASS

Execution class in accordance with ISO 8528/5 (2005) taking into account the behaviour of the generator set in a permanent mode of operation with different load levels, as well as in a temporary mode of operation due to shocks in the load.

Performance class	G2
--------------------------	----

■ REGULATION

The generator set has a CE Marking that includes the following directives:

- 2006/42/CE Machine Safety.
- 2006/95/CEE Low Voltage.
- 2004/108/CE Electromagnetic compatibility.
- 97/68/CE Gases and contaminating particles emissions.
- 2005/88/CE Noise emissions of machines outdoors in soundproof generator sets.

Applicable international regulations:

- ISO 8528
- ISO 3046
- BS 5000
- IEC 60034

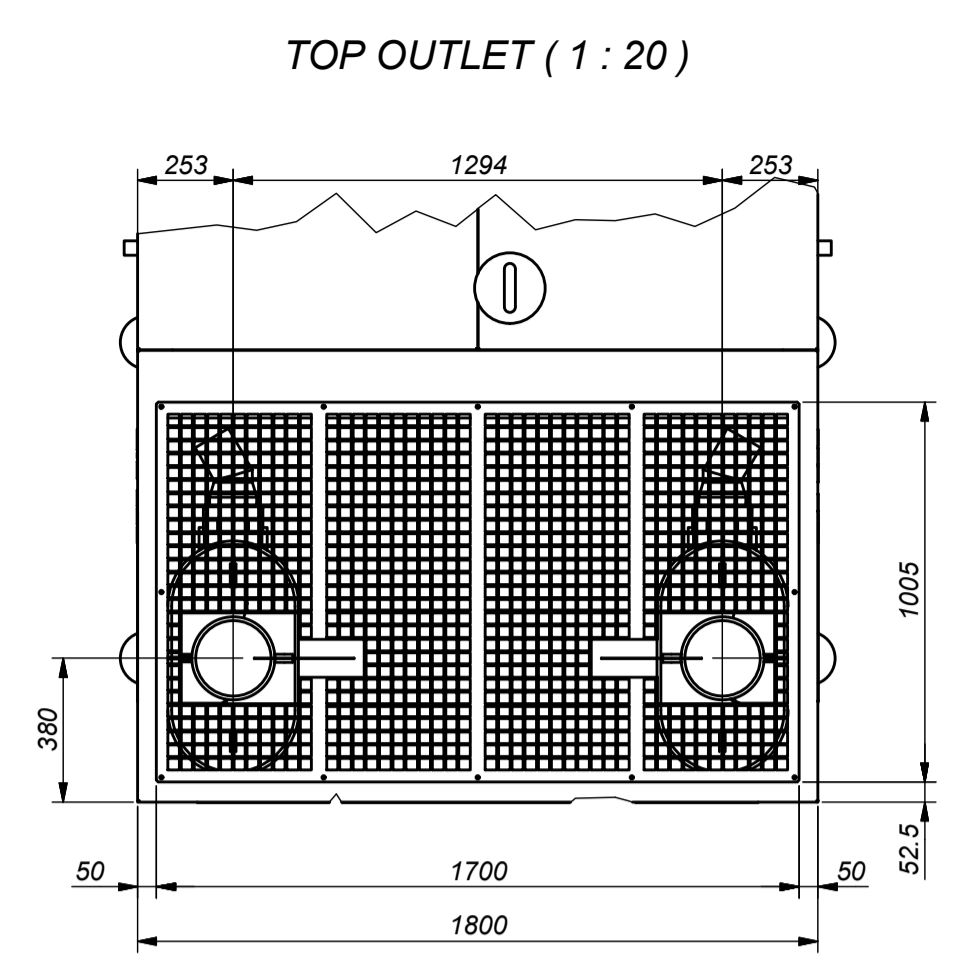
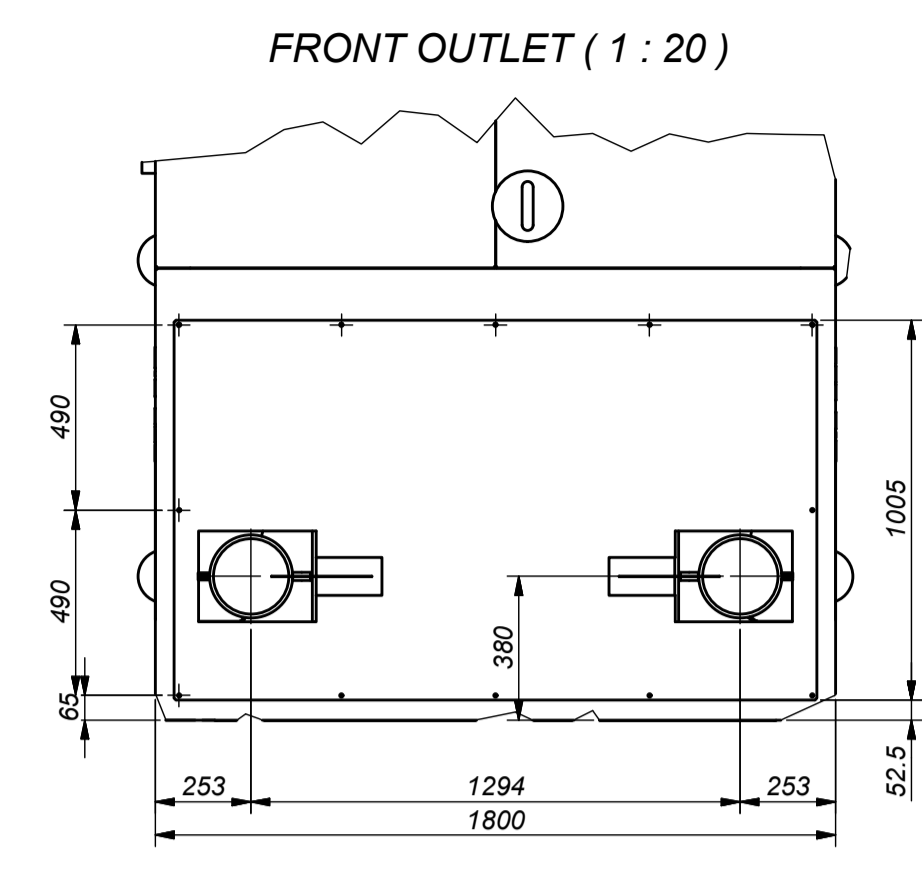

ISOMETRIC TOP VIEW (1:30)

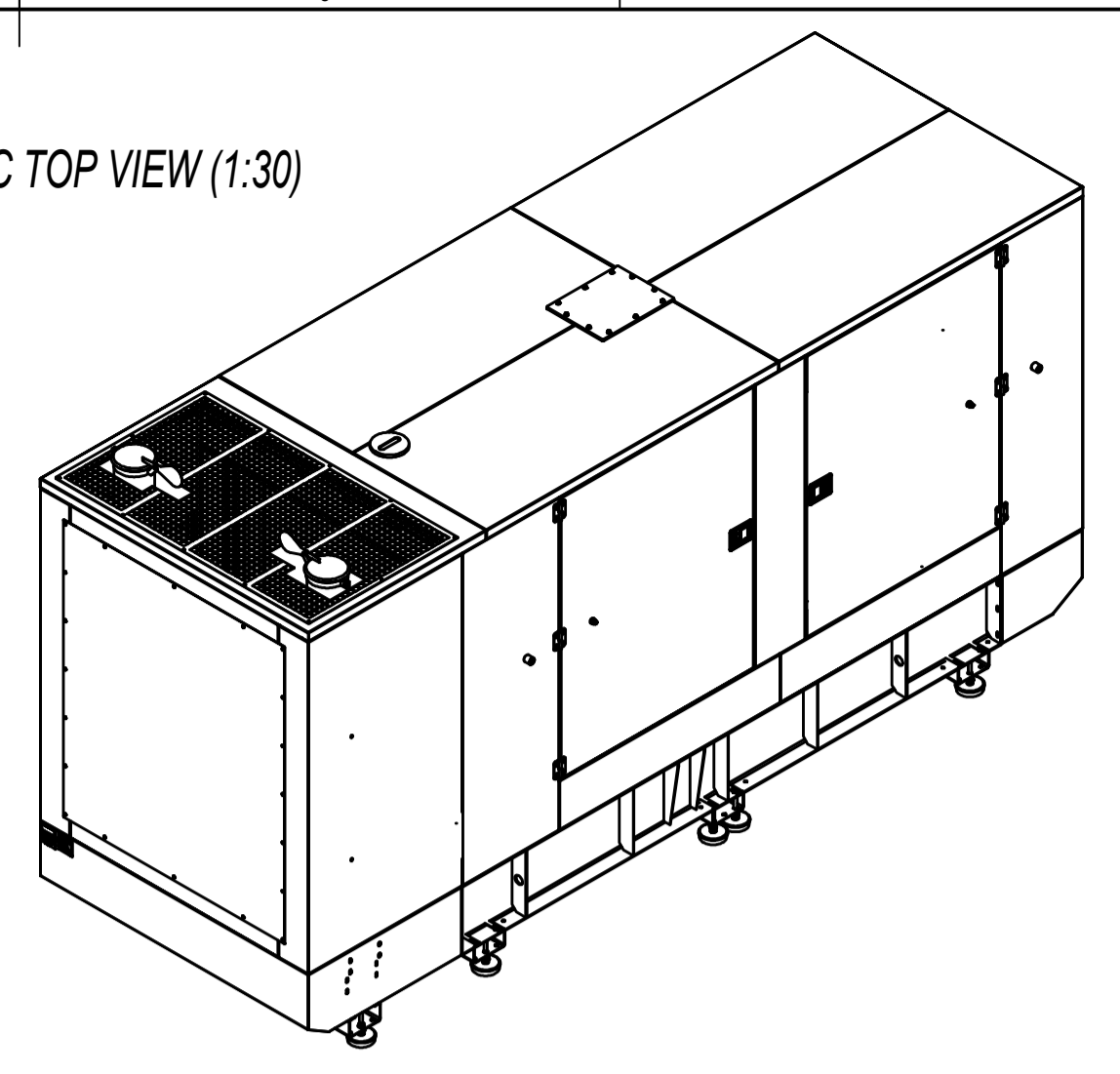

ISOMETRIC FRONT VIEW (1:30)

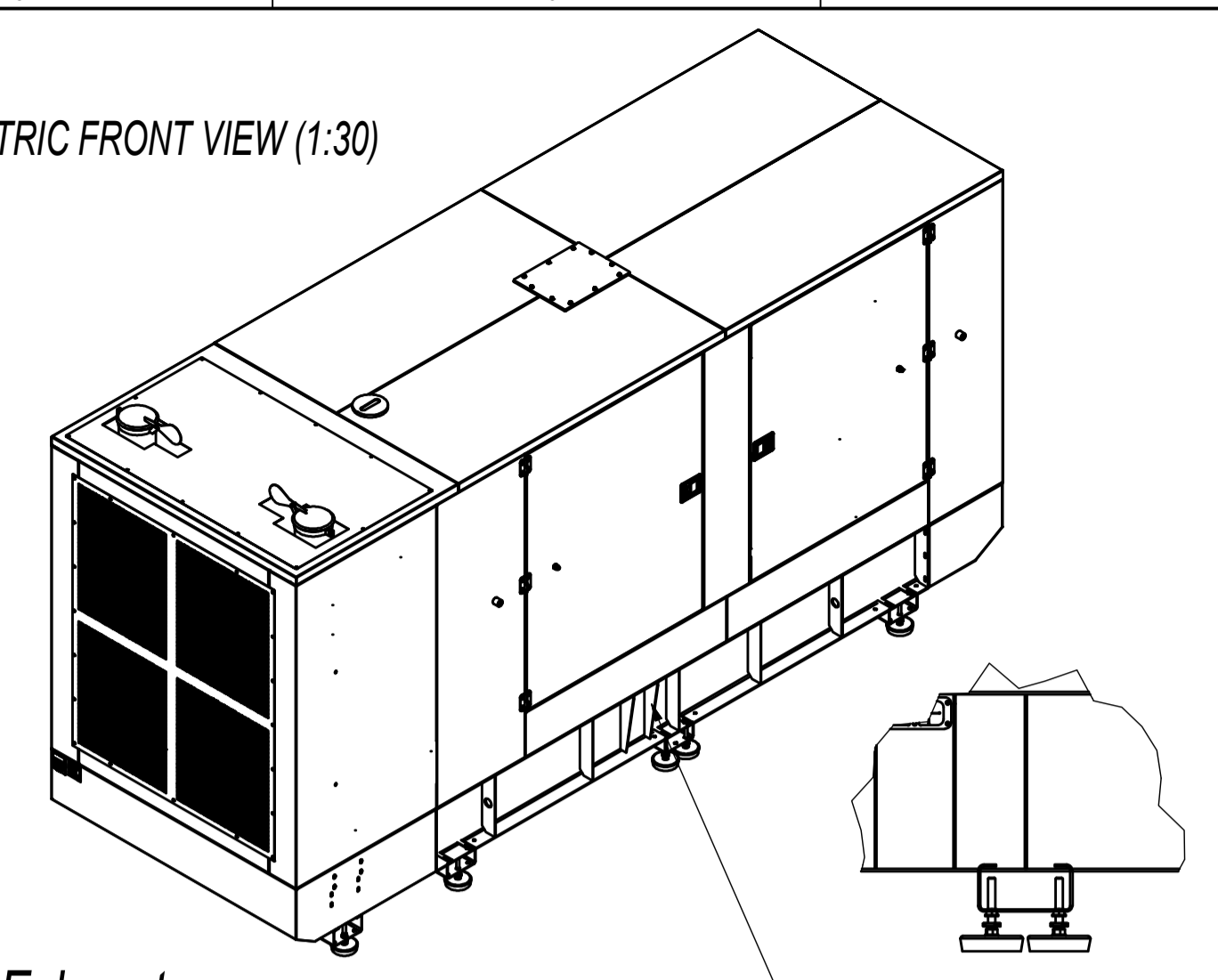

External Fuel Tank connections (EFT)

Cooling Air / Exhaust OUTLET
↑↑↑↑

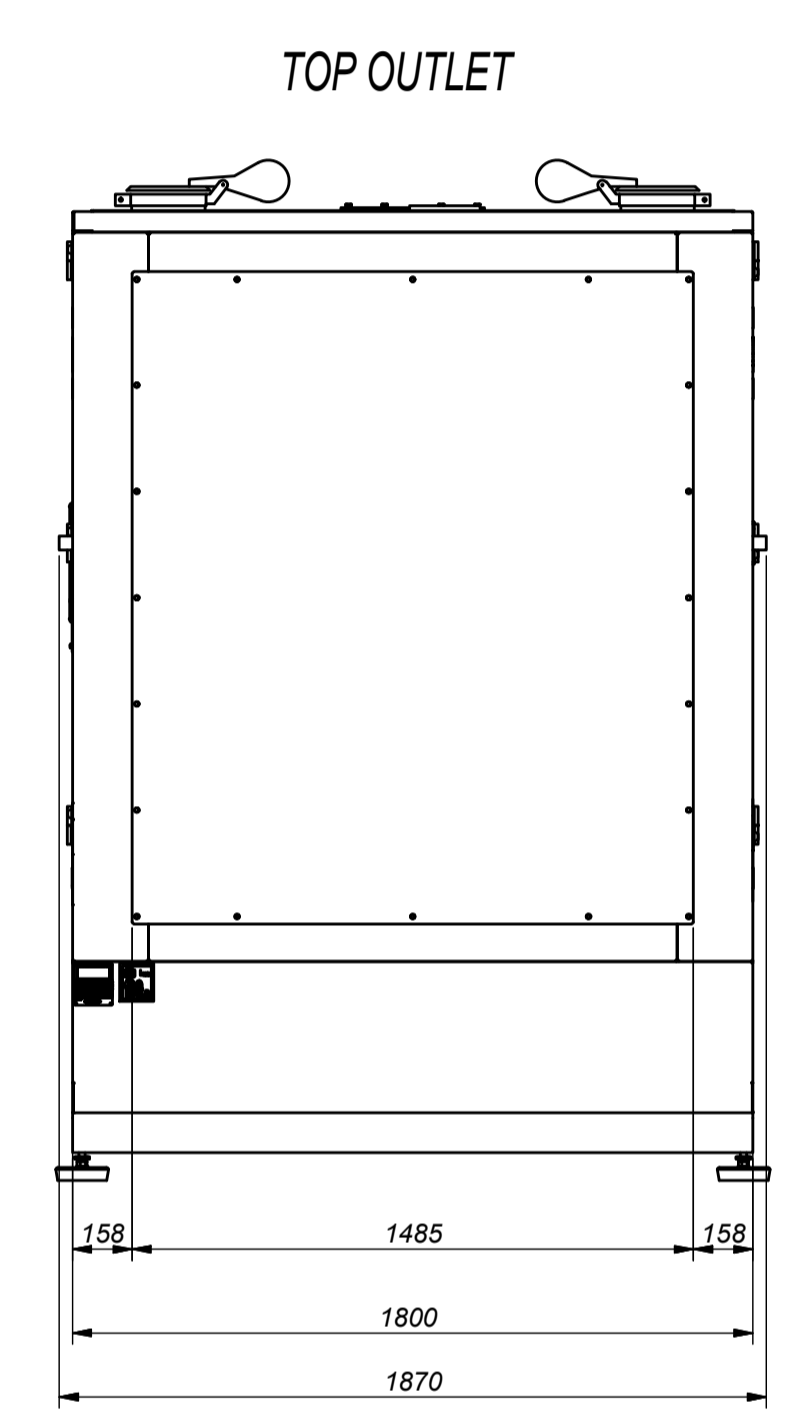
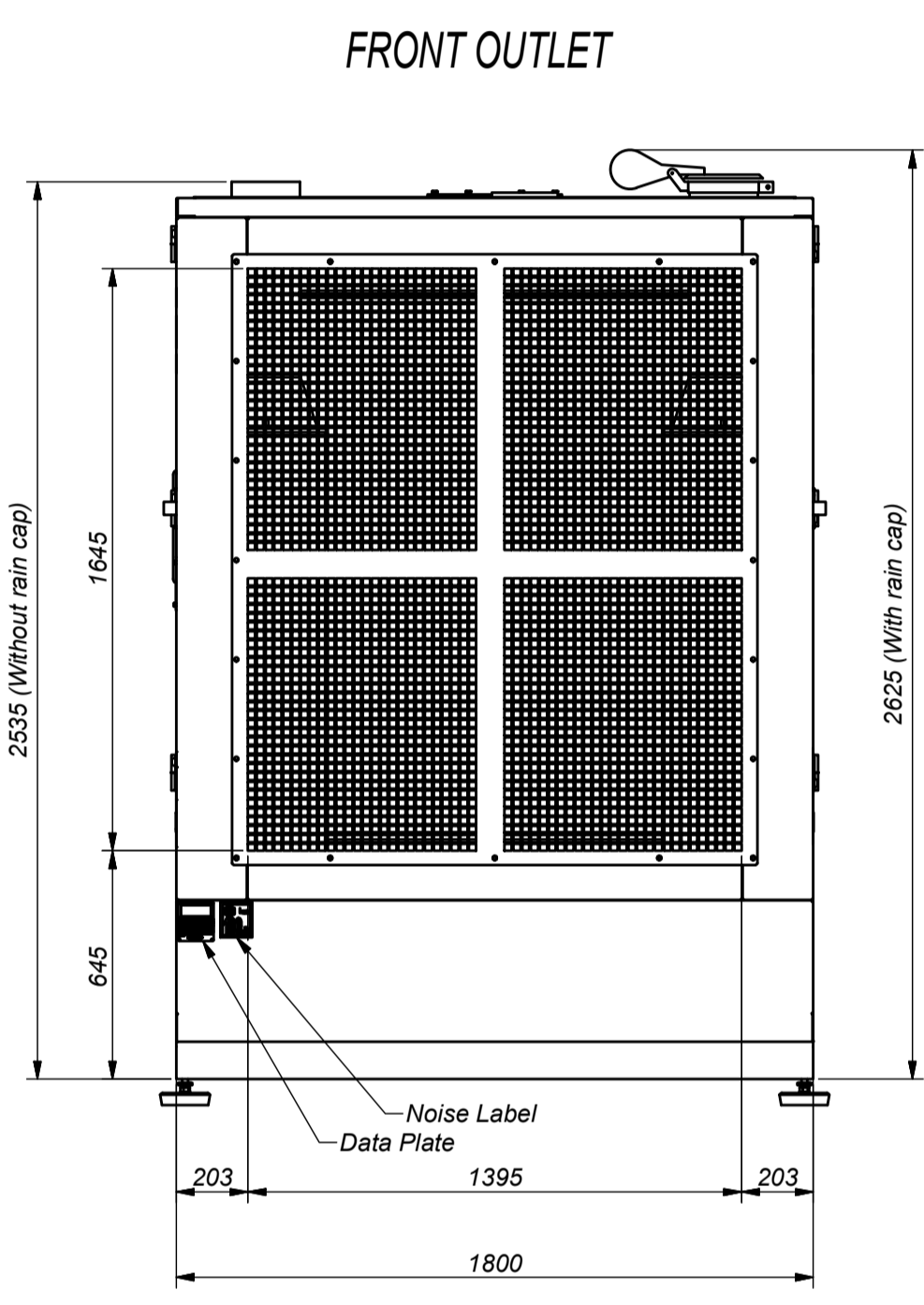

Cooling Air Inlet

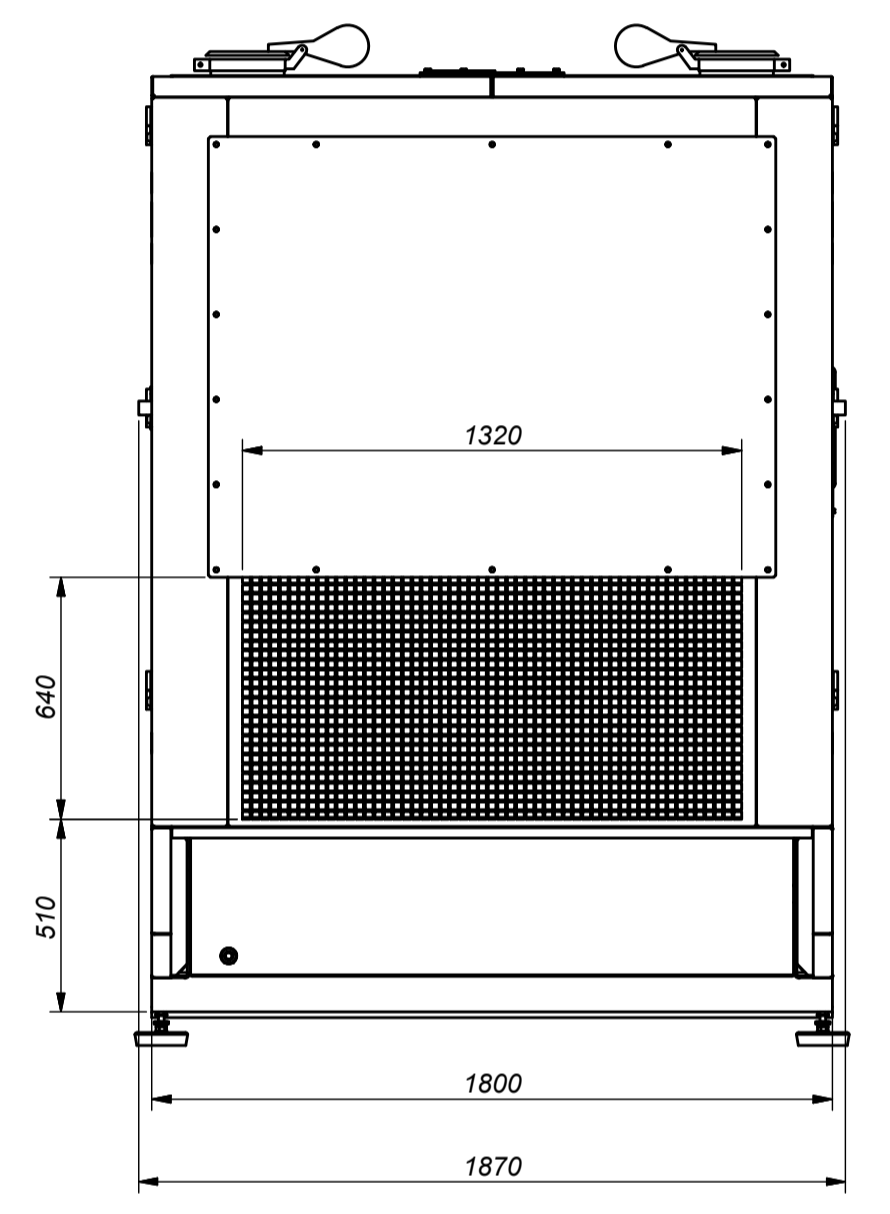
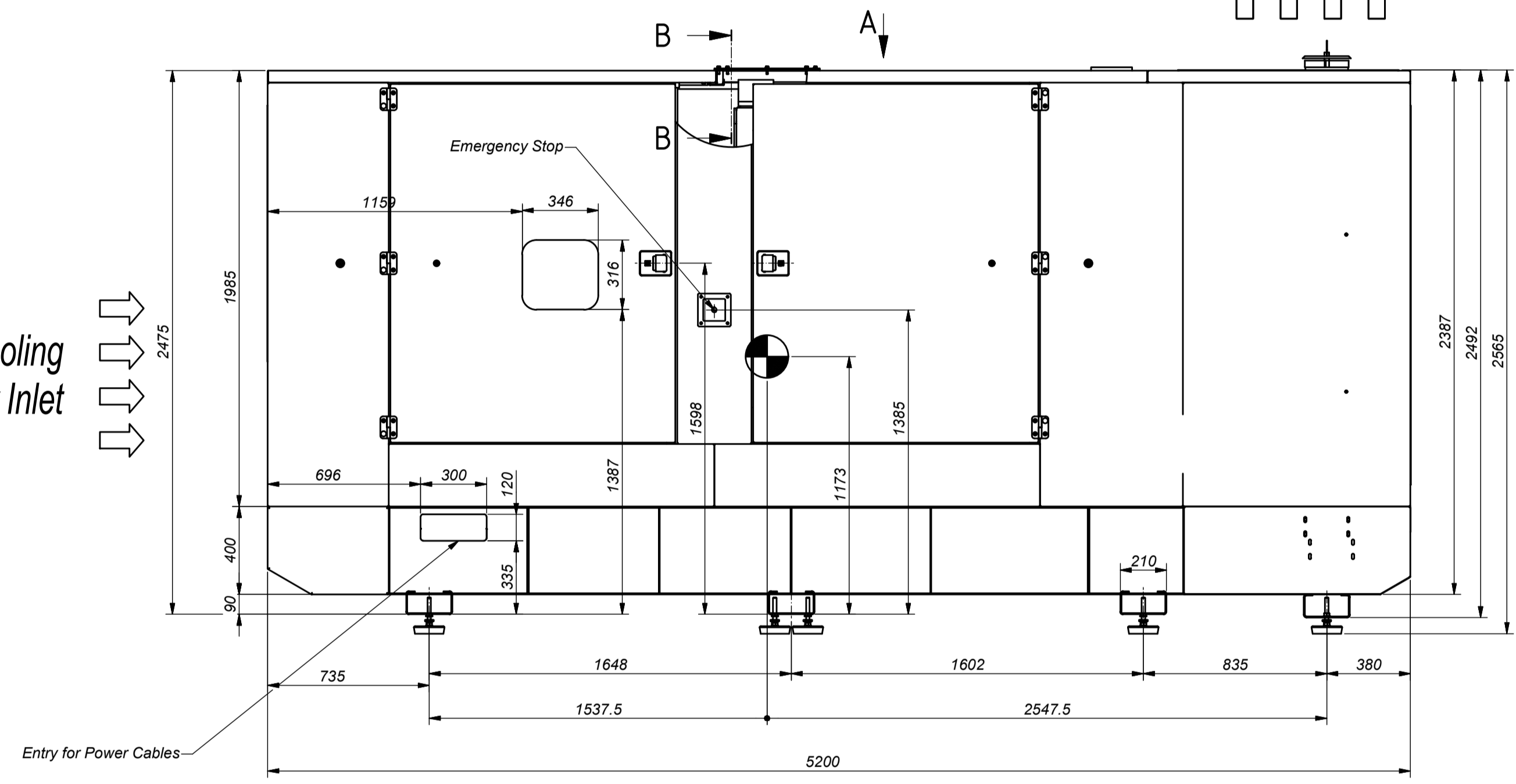
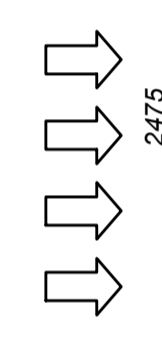

MAINTENANCE SPACE (1:30)

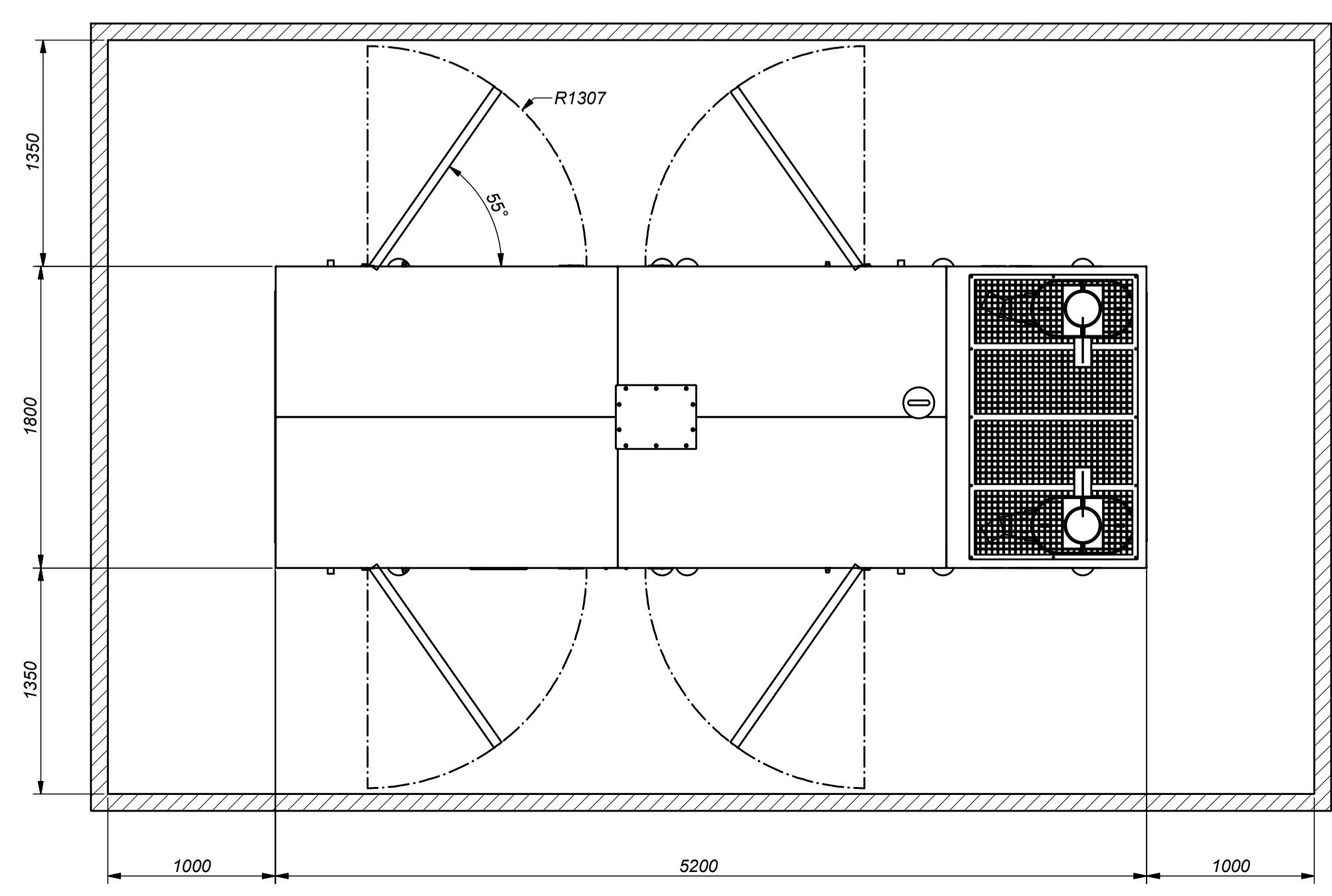

A (1:30)

Cooling Air Inlet

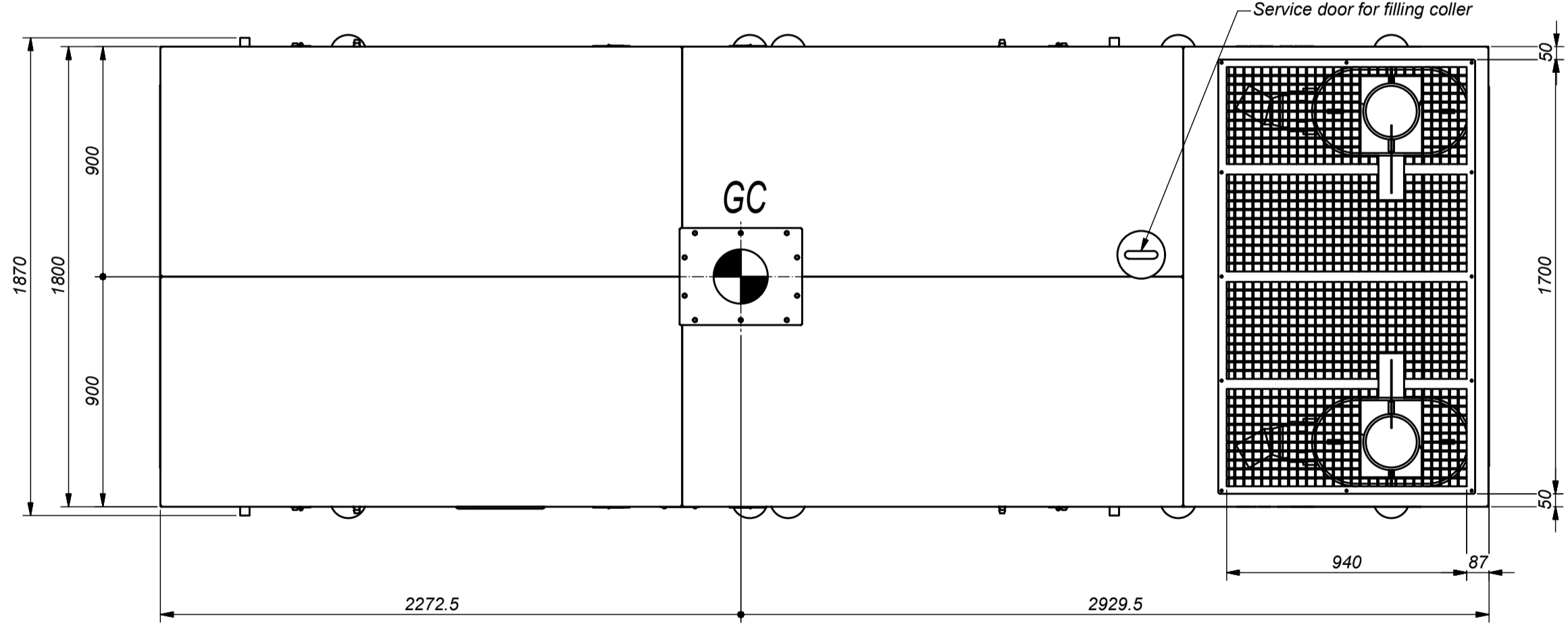
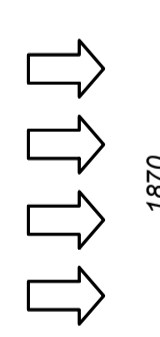

ALIGN CUBICLES WITH CUBICLES SUPPORT

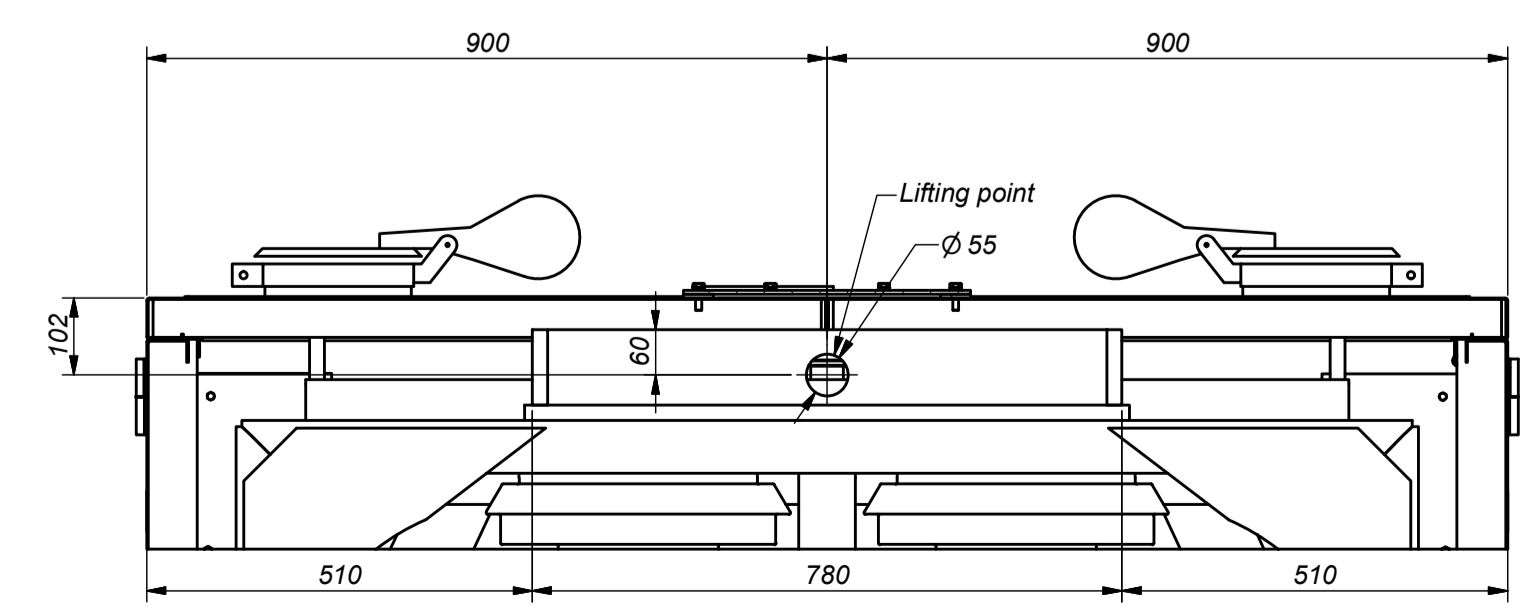
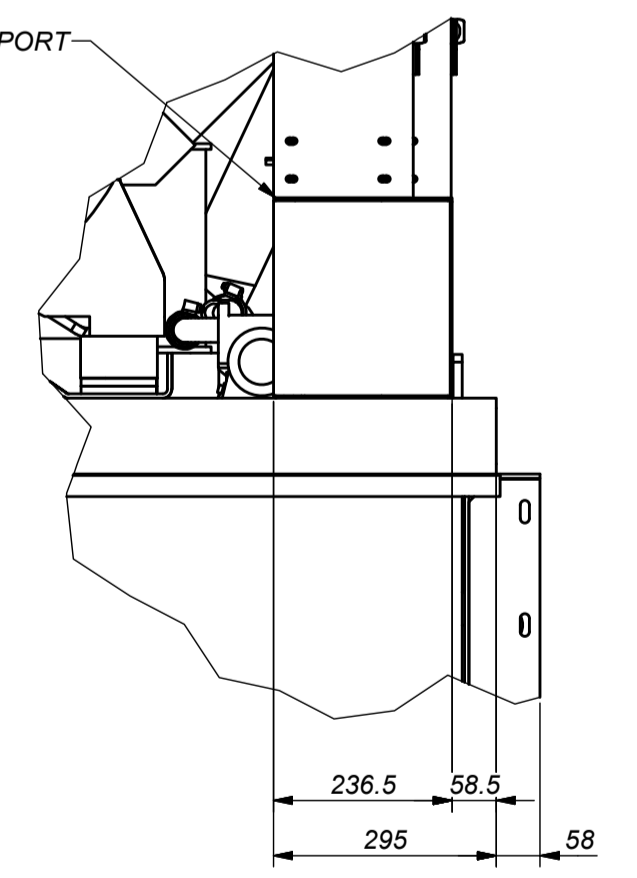

B-B (1:10)

MODEL TABLE			
(50 HZ) KVA	(60 HZ) KVA	(50 HZ) KW	(60 HZ) KW
735	710	680	645
830	740	750	675

TOTAL APROX. WEIGHT with empty tank = 6355 kg
Capacity tank : 1293 liters

All materials supplied are in compliance with the requirements of the List of Prohibited Substances

Tolerances, if not indicated, according to: General tolerances 1350K - mK

Name	DIMENSION DRWG		MODEL (SEE DRAWING)	Confidentiality Class acc. to 1102 K
Material				Confidential
Treatment			Thickness: INV	Drawing owner
Scale	Family	A1	Compare	ESF
Drawn by	Blank nr.		Replaces	
Version Drwg	Blank wt		Designation	Sheet 1 / 3
STATUS	Des checked.	Prod checked.	Approved.	Date 28/01/2014
3802426	05	17894.399 Kg	1633026383	
Parent 3D model	Ed - Version 3D	Approved		

CONFIDENTIAL: This document is our property and shall not be distributed without our prior permission. All rights reserved. No part of this document may be reproduced, stored in a retrieval system, or transmitted in any form or by any means, electronic, mechanical, photocopying, recording, or by any information storage and retrieval system, without the prior written permission of the owner.

00	Position	Modified from	09/12/2014	jamiguel
Ed		Date	Intr./Appr.	

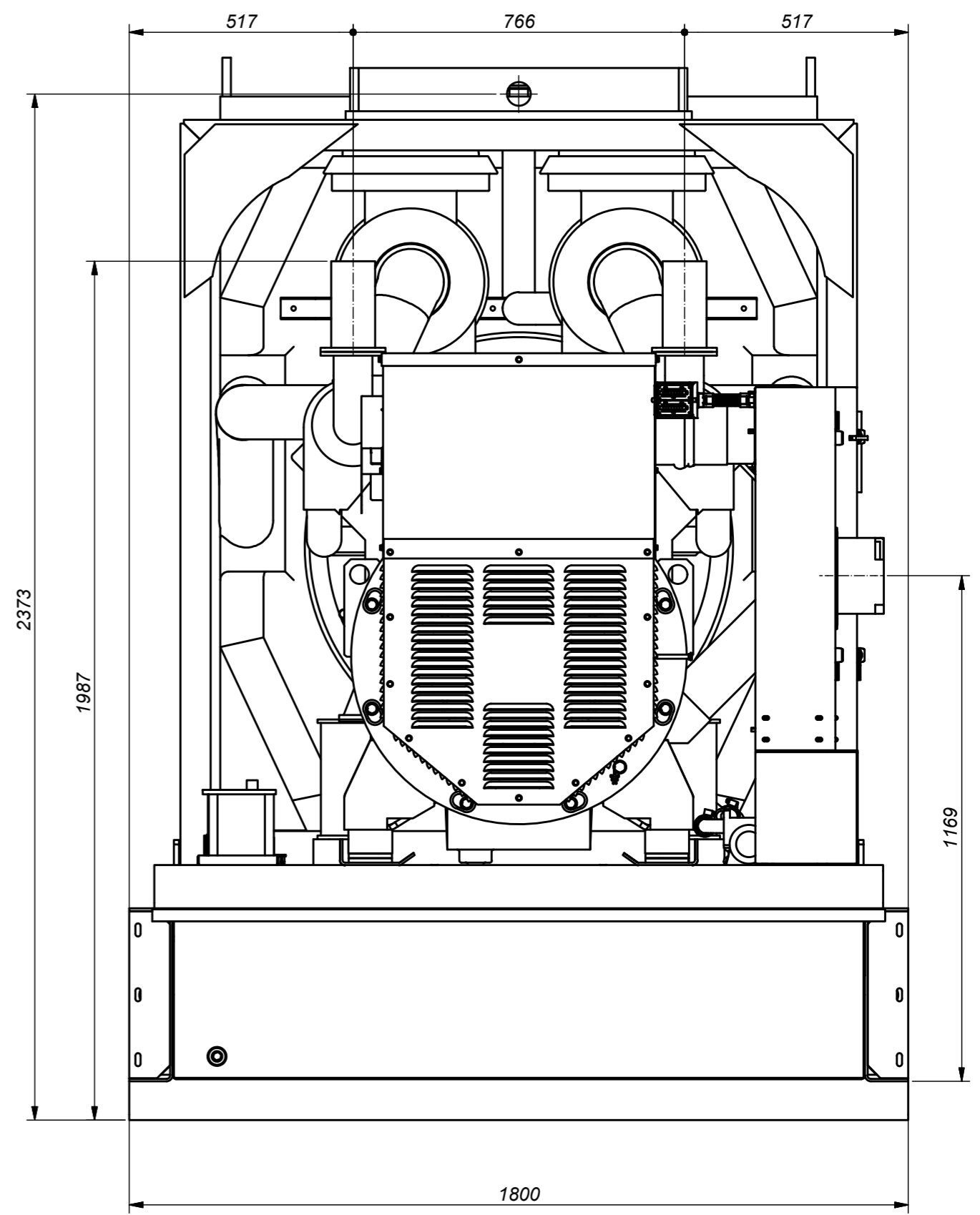
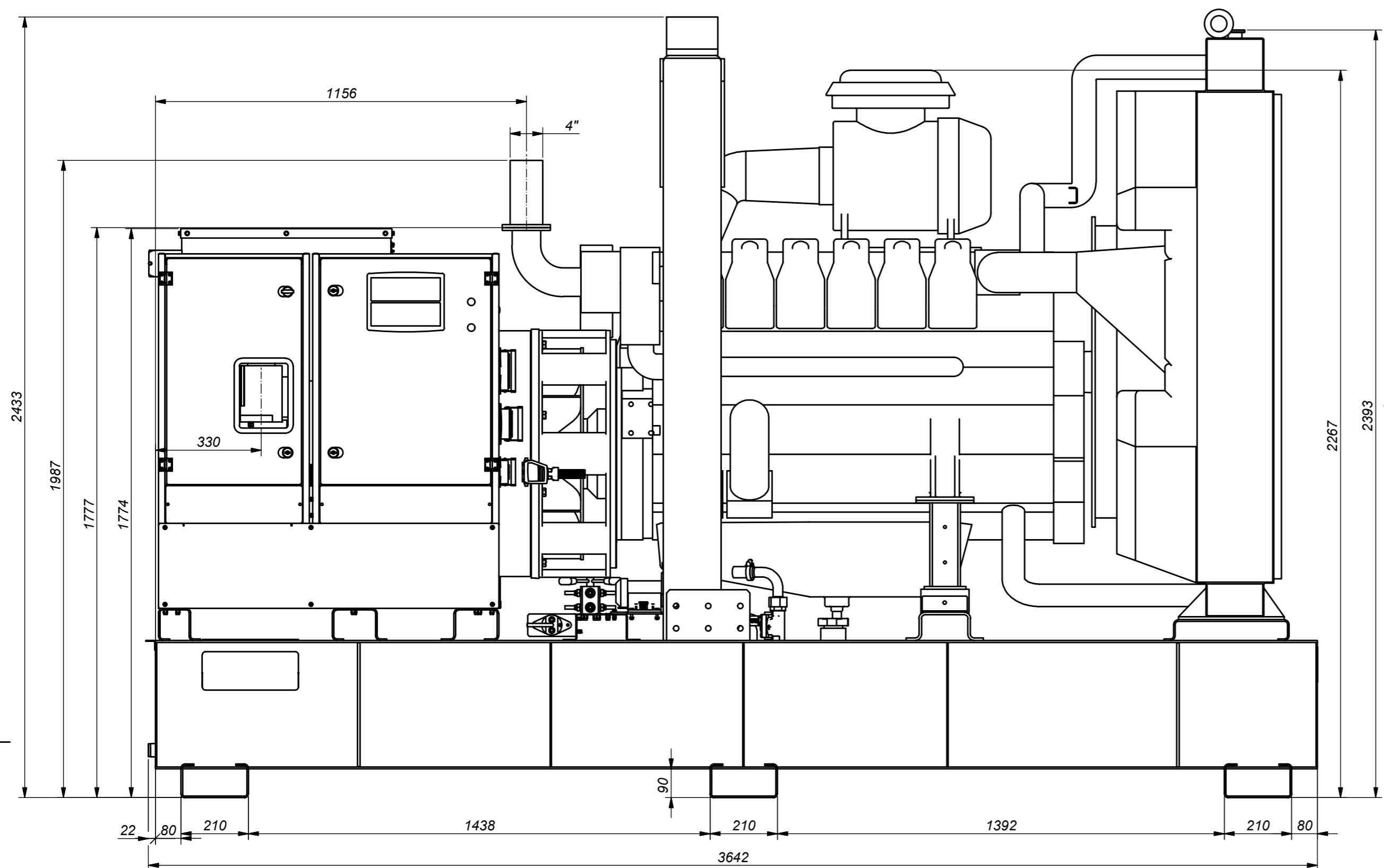

ENGINE DP222 (1 : 12.5)

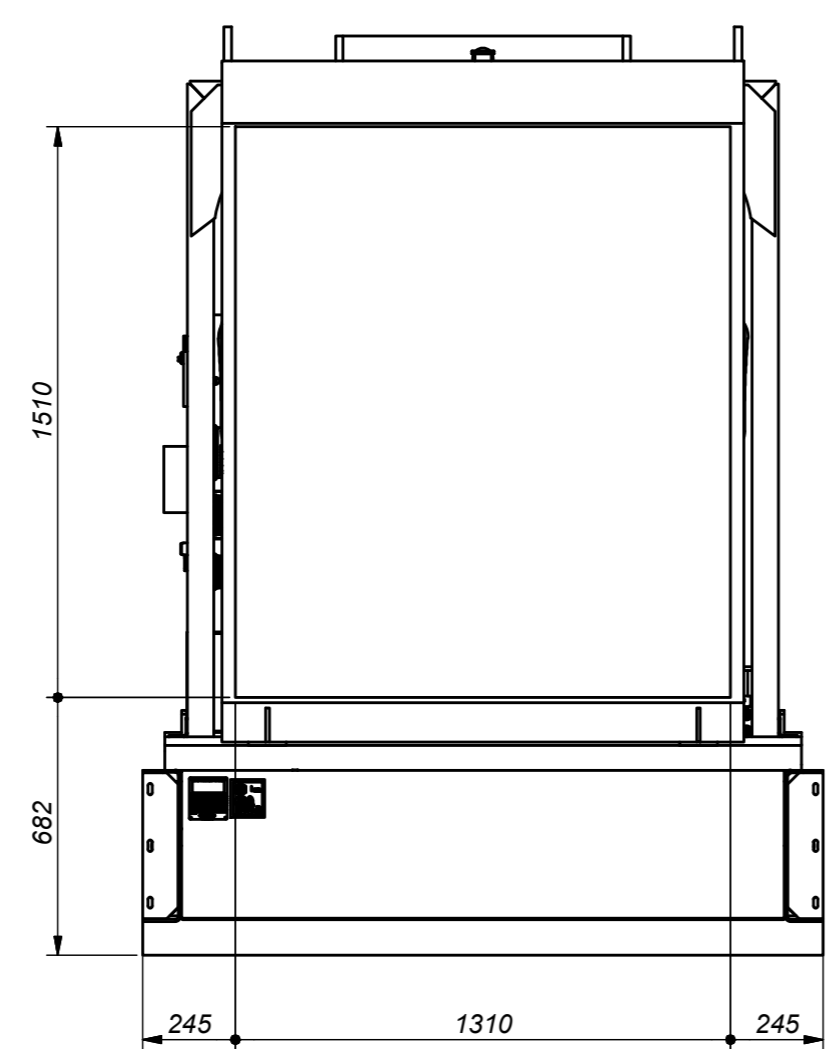

A (1 : 20)

TOTAL APROX. WEIGHT with empty tank = 5315 kg
Capacity tank : 1293 ltrs

All materials supplied are in compliance with the requirements of the List of Prohibited Substances

Tolerances, if not indicated, according to:		General tolerances			
		1350K - mK			
Name		DIMENSION DRWG		MODEL (SEE DRAWING)	
Material				Confidentiality Class acc. to 1102 K	
Treatment				Confidential	
				Thickness: INV	
Scale		Family		A2 Compare	
Drawn by saranda		Blank nr.		Replaces	
Version Drwg 00		Blank wt Kg		Fini wt. 17894,399 Kg	
STATUS		Des checked.		Prod checked.	
Approved		Approved.		Date 28/01/2014	
Parent 3D model		Ed . Version 3D		Designation	
3802426		05		1633026383	
Ed		Position		Drawing owner	
Modified from		Date		ESF	
09/12/2014		jamiguel		Sheet 2 / 3	
Intr./Appd.					

CONFIDENTIAL:

This document is our property and shall not, without our permission, be altered, copied, used for manufacturing or communicated to any other person or company.

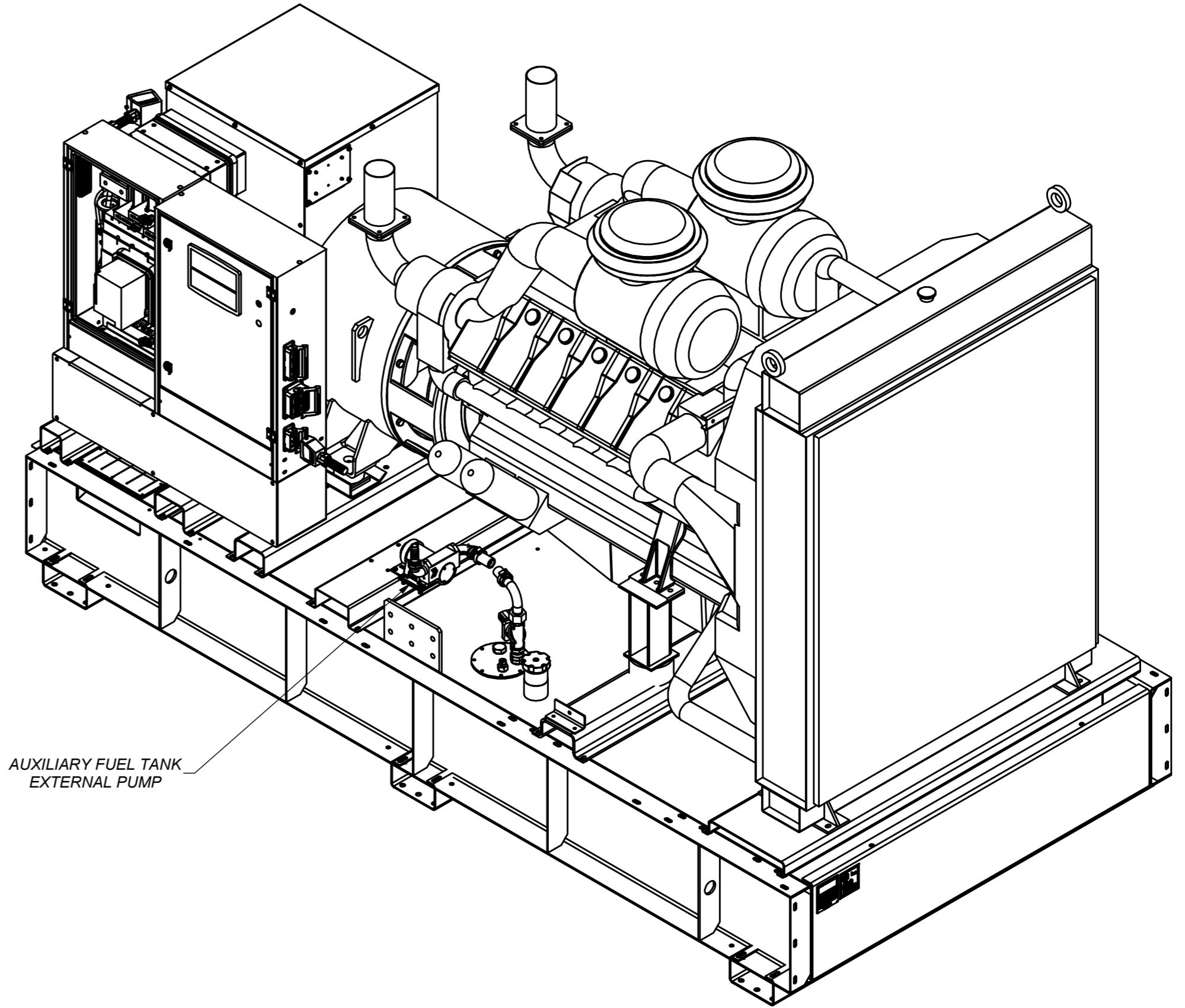
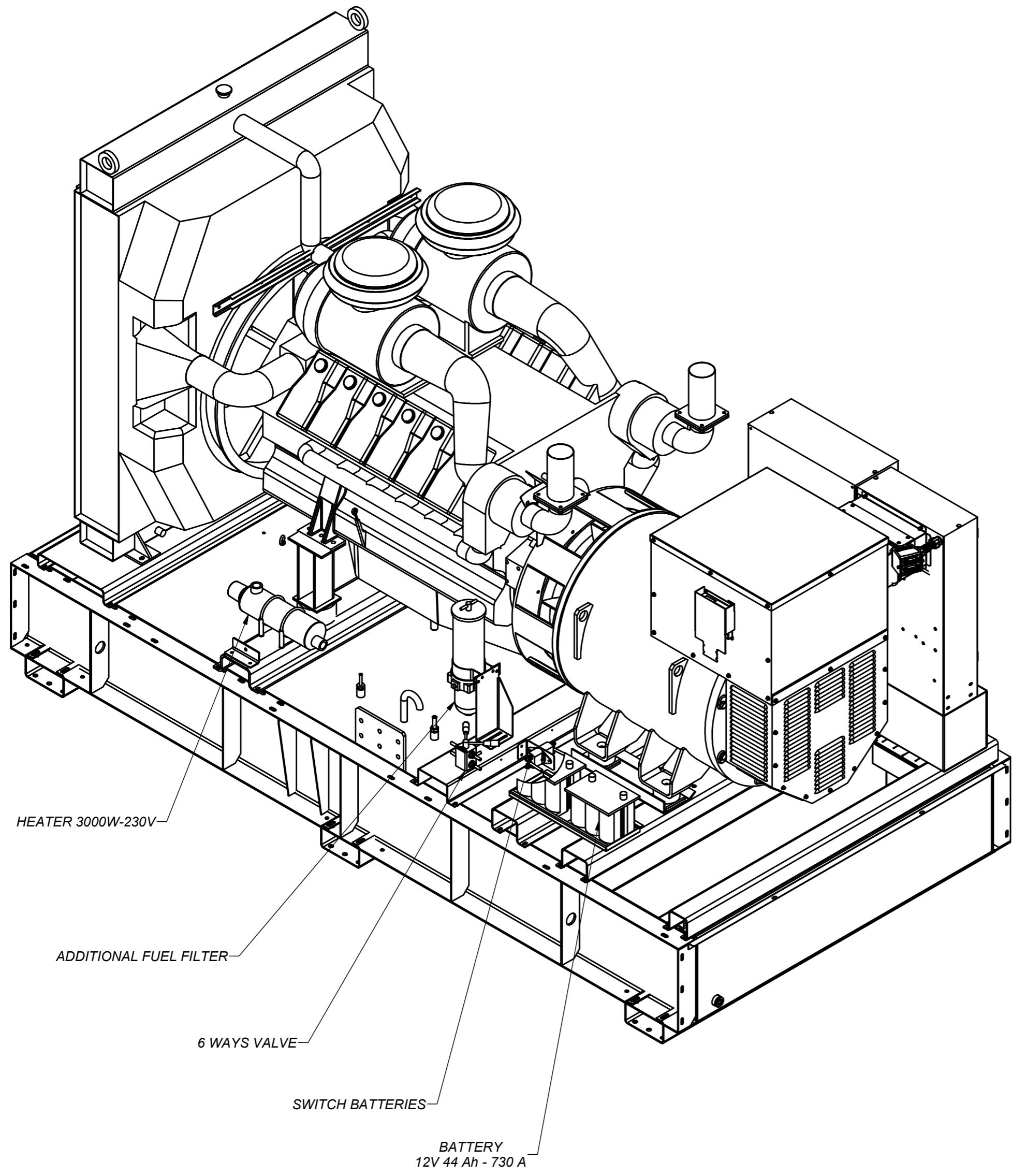

All materials supplied are in compliance with the requirements of the List of Prohibited Substances

Tolerances, if not indicated, according to:		General tolerances			
		1350K - mK			
Name		DIMENSION DRWG		MODEL (SEE DRAWING)	
Material				Confidentiality Class acc. to 1102 K	
Treatment				Confidential	
				Thickness: INV	
Scale		Family		A2 Compare	
Drawn by saranda		Blank nr.		Replaces	
Version Drwg 00		Blank wt Kg		Fini wt. 17894,399 Kg	
STATUS		Des checked.		Prod checked.	
Approved		Approved.		Date 28/01/2014	
Parent 3D model		Ed. Version 3D		Designation 1633026383	
				Sheet 3 / 3	

CONFIDENTIAL

This document is our property and shall not, without our permission, be altered, copied, used for manufacturing or communicated to any other person or company.

00			09/12/2014	jamiguel
Ed	Position	Modified from	Date	Intr./Appd.